

DOCUMENT RESUME

ED 043 838

AC 008 637

TITLE Museum Techniques in Fundamental Education.
INSTITUTION United Nations Educational, Scientific, and Cultural Organization, Paris (France).
REPORT NO ESD-17-A
NOTE 57p.
AVAILABLE FROM Unesco Publications Center, 152 West 42nd. Street, New York 36, N.Y. (Available in English or French)

EDRS PRICE EDRS Price MF-\$0.25 HC-\$2.95
DESCRIPTORS *Adult Basic Education, Agriculture, Animal Science, *Audiovisual Aids, Conservation Education, *Developing Nations, *Educational Programs, Exhibits, Forestry, Handicrafts, Health Programs, Horticulture, Lighting, Maintenance, *Museums, Pictorial Stimuli, Recordkeeping, Technical Assistance, Traffic Circulation

IDENTIFIERS India

ABSTRACT

Some museum techniques and methods can be used in fundamental educational programs without elaborate buildings or equipment; exhibitions should be based on valid presumptions and should take into account the "common sense" beliefs of people for whom the exhibit is designed. They can be used profitably in the economic development of local cultural resources, as shown in the revival of pottery manufacture in the American Indian pueblo of San Idlefonso. Exhibitions can be used to aid programs in the basic principles of contemporary science, techniques in agriculture, the development of new industry, as well as the development of public health and literacy. The scope of material which can be used for exhibition purposes is nearly inexhaustible; it should be selected for size and weight for an exhibition for fundamental education purposes should be mobile in order to reach the widest audience. Collections may be acquired by purchase, gifts, or loan; records are essential. In Mysore (India) two exhibitions were conducted by a Unesco team--one on trees and the soil in an area of little rainfall and one on market gardening. They confirmed the opinion of the great value of the audiovisual model boxes and the importance of oral explanations. (EB)

U.S. DEPARTMENT OF HEALTH, EDUCATION
& WELFARE

OFFICE OF EDUCATION

THIS DOCUMENT HAS BEEN REPRODUCED
EXACTLY AS RECEIVED FROM THE PERSON OR
ORGANIZATION ORIGINATING IT. POINTS OF
VIEW OR OPINIONS STATED DO NOT NECES-
SARILY REPRESENT OFFICIAL OFFICE OF EDU-
CATION POSITION OR POLICY.

educational studies and documents

No **17**

Museum Techniques in Fundamental Education

u n e s c o

EDUCATIONAL STUDIES AND DOCUMENTS

Published in English, French and – for titles marked with an asterisk – in Spanish

- *I – *Report on the Unesco La Brévière International Seminar on Workers' Education*, by G.D.H. Cole
- II – *African Languages and English in Education*
- III – *How to Print Posters*, by Jerome Oberwager
- IV – *Bilateral Consultations for the Improvement of History Textbooks*
- V – *Methods of Teaching Reading and Writing: a preliminary survey*, by William S. Gray
- VI – *Modern Languages in the Schools* (Out of print)
- *VII – *Education for Community Development: a selected bibliography*
- *VIII – *Workers' Education for International Understanding*, by Asa Briggs
- IX – *Experiments in Fundamental Education in French African Territories*
- *X – *The Use of Social Research in a Community Education Programme*
- *XI – *Some Methods of Printing and Reproduction*, by H.R. Verry
- *XII – *Multiple-Class Teaching*, by John M. Braithwaite and Edward J. King
- XIII – *A bibliography on the Teaching of Modern Languages*
- XIV – *Adult Education in Turkey*, by Turhan Oğuzkan
- *XV – *Fundamental, Adult, Literacy and Community Education in the West Indies*, by H.W. Howes
- XVI – *Some Studies in Education of Immigrants for Citizenship*

In the field of education Unesco also publishes the following periodicals:

EDUCATION ABSTRACTS

Published monthly, except July and August, in English, French and Spanish editions. Each number consists of a bibliographical essay on a particular aspect of education and a number of abstracts of recent publications dealing with the same topic, Annual subscription: \$1.75; 9s.6d.; 450 Fr. francs.

FUNDAMENTAL AND ADULT EDUCATION

A quarterly bulletin in English, French, Spanish and Arabic editions. Articles of interest to educators and administrators on the theory and practice of fundamental and adult education, and description of programmes, field work and materials used.

Annual subscription: \$1.00; 5s.; 250 Fr. francs.

Any of the national distributors listed on page 4 of this cover will be pleased to accept subscriptions and to quote rates in currency other than the above.

ESD/17/A

Printed in the Workshops of the
United Nations Educational, Scientific and Cultural Organization
19, Avenue Kléber, Paris - 16e.

ED043838

Museum Techniques in Fundamental Education

UNESCO, PARIS

P R E F A C E

In publishing the two essays that make up the present volume, the Unesco Secretariat does not claim to have produced a manual; the aim has been the more modest one of giving some idea of how museum techniques can be used to advantage in programmes of social and economic development among illiterate or semi-literate peoples. If the authors,¹⁾ in their capacity as experts, have offered various practical suggestions and described concrete experiments, they are none the less convinced that the application of museum techniques to fundamental education is still largely a matter for conjecture. It is hoped that this publication,²⁾ by encouraging others to go more deeply into the question, will help to turn conjecture into an organized body of ideas based on experience.

-
- 1) *Part I was written by H. Daifuku, programme specialist in the Museums Division of Unesco. Mr. Daifuku was formerly Curator of the State Historical Society Museum, Madison, Wisconsin, U.S.A., which specializes in exhibitions of Northwest Coast Indian, Eskimo and South Western Pueblo cultures. Part II is by J.B. Bowers, Head of the Fundamental Education Division, Unesco, and is based on experience gained in India, where the writer was Director of the Unesco Group Training Scheme for Specialists in Fundamental Education, Mysore, 1953-55. This Scheme is briefly described by Mr. Bowers at the beginning of his essay.*
 - 2) *Together with two other studies on the rôle of museums in education - Education Abstracts, Vol. VIII, No. 2, February 1956, and Fundamental and Adult Education, Vol. VIII, No. 2, April 1956 - the present work is intended as a contribution to the International Campaign for Museums which is being organized in 1956 by the International Council of Museums (I.C.O.M.).*

TABLE OF CONTENTS

	<u>Page</u>
<u>PART I: MUSEUM TECHNIQUES IN FUNDAMENTAL EDUCATION: GENERAL CONSIDERATIONS</u>	
Introduction	4
Chapter I. The Relevance of Museum Techniques to Three Programme Areas	
A. Arts and Crafts	6
B. Technical Assistance Problems	10
C. Health Programmes	13
Chapter II. The Exhibition: Some Principles and Practical Suggestions	15
Chapter III. The Collections	25
Conclusions	32
Selected Bibliography	33
<u>PART II: MUSEUM TECHNIQUES IN FUNDAMENTAL EDUCATION: THE MYSORE EXPERIMENTS</u>	
Chapter I. Planning the Exhibition	35
Chapter II. Constructing the Exhibition	44
Chapter III. The Exhibition Completed: an Appraisal	49
Chapter IV. A Second Experiment in Mysore	50
Conclusions	52

PART I

MUSEUM TECHNIQUES IN FUNDAMENTAL EDUCATION: GENERAL CONSIDERATIONS

INTRODUCTION

There is a prevalent impression that art museums are "ivory tower" institutions - large impressive buildings filled with the treasures of the ages - through which pass hushed crowds of reverent admirers. On the other hand natural science museums or archaeological museums are usually thought to be musty old buildings characterized by an odour of formaldehyde and moth crystals and filled with dusty cases of stuffed birds, skeletons, or a meaningless profusion of stone implements and other relics of the past.

Such museums may not be without interest, but they tend to attract audiences who are already aware of the background of the things shown. Museums would be of small benefit to a fundamental education programme if they offered only collections to be viewed - particularly if the collections could be appreciated only through prior detailed study. While these stereotyped conceptions of museums may still hold true for some institutions, there has been a rapid change in recent years. Museums in many countries can no longer be considered sanctuaries for the connoisseur or specialist. They are actively engaged in revising exhibition policies and relations with the public at large, and play a more important rôle in general education. Many specialists in educational work, however, may not be aware of the possibilities of the methods that have been developed.

The effectiveness of museum educational programmes is based on the simple principle that visual experience may often be more easily remembered than a written or verbal description of an object. In general terms, museum exhibitions are simply a specialized type of visual aid. There are, of course, certain significant differences between museum exhibitions and other types of visual aid. Museums usually start as research institutions or develop from collections in which exhibition has been a secondary consideration. Although exhibition is no longer considered unimportant, research continues to be emphasized, and detailed study, in fact, underlies most museum exhibitions. This too, has had its effect, for in view of the amount of preparatory work involved exhibitions are usually planned for several years' use. It is true that temporary exhibitions are becoming more common, but they too are usually shown for a longer period than other visual aid devices. For a given amount of exhibition space, museum exhibitions tend to be more expensive than other types of visual aids. Museum exhibitions differ also in their insistence on the use of original material rather than copies or photographs. Photographs, charts and diagrams are used as supplementary and explanatory devices but usually not as the principle exhibition device. Models and dioramas are also used to make explanations clearer or to give three dimensional reality to collections.

In recent years the didactic or instructional exhibit has become much more common among museums. Cases are no longer filled with scores of birds of the same species merely to illustrate regional variation of interest only to an ornithologist. Instead, birds may be used to illustrate principles of evolution, of flight, or of migration patterns. In other words, collection and the accumulation of detail are now no longer ends, but means. The exhibit is oriented to raise questions and to stimulate thought as well as to explain.

Organized educational programmes have also become increasingly common. Some are very elaborate and require a full-time specialized staff to teach classes for children of different age levels held after school hours or on week-ends. Some programmes are, in fact, integrated with the school curricula of the local community and, in many instances, with surrounding communities as well. Many museums have adult education courses, and a few specialized museums deal with particular aspects of fundamental education.

Some museum techniques and methods can be utilized successfully in fundamental educational programmes without elaborate buildings or equipment. For the most part, museum programmes are carried out among literate populations, but in several areas experience has been gained with

non-literates. With slight modifications, it has been found that the principles used to explain complex problems and concepts visually and simply to casual visitors at a museum can also be applied to non-literate populations. Museum techniques can be profitably used in:

- (1) The economic development of local cultural resources;
- (2) The improvement of technology for a more efficient exploitation of the environment, e.g. the teaching of agricultural practices, reforestation, crop rotation, etc.;
- (3) Health education.

The full potentialities of museums and the use of museum techniques in education, have, of course, yet to be realized. In many instances museums may not be altogether aware of the needs of educators and many educators may be using visual aids which parallel the work done by some museums without realizing that museums have been working on such problems for years and may be in a position to give them practical aid or advice.

Before examining some of the practical aspects of the techniques, it may be useful to show how these can be used in certain programme areas common to museums and fundamental education work.

CHAPTER I

THE RELEVANCE OF MUSEUM TECHNIQUES TO THREE PROGRAMME AREAS

A. ARTS AND CRAFTS

The problems of the people of a technically less advanced culture undergoing acculturation⁽¹⁾ have been extensively documented in anthropological literature. While acculturation is usually a two-way process, the changes which occur in the culture of the technically less advanced group are much more radical. These changes are taking place with great rapidity under present conditions of improved communication, heightened economic interdependence and political nationalism. A group of people may show active resistance or they may feel a strong drive to acquire all of the more advanced techniques possible or there may result a mixture of these conflicting impulses.

Handicrafts under such conditions are frequently discouraged as being 'native' and backward. Therefore, the individual who wishes to restore or to continue the production of a folk art or some form of handicraft may be confronted with several problems beyond the mere technological one of the continuation of particular skills. Clearly, hand-made articles cannot compete directly with the products of an industrialized economy. For example, it may take a woman many months to weave enough cloth for a dress; in terms of time and labour it would be much less expensive for her to purchase the cloth needed from the merchant in the market place. Moreover, in some countries, to wear hand-woven cloth and native costume can be socially undesirable since the adoption of 'Western' dress is taken to be an external manifestation of the desired industrialization of the country.

One way in which the harmful effects of acculturation might be attenuated is to encourage the continuity in the new culture of certain elements of the old. Among these continuing elements the folk arts and crafts would seem to be important. But, if they are to survive, they must find their place in contemporary economy. The producer will have to obtain sufficient psychological and monetary compensation to make the venture worth while. Acculturation under such circumstances inevitably means a shift to money economy and any attempt to revive a handicraft must take this fact into account.

In a world in which mass produced articles are becoming much more common and where their relative cost to the consumer is low, foreign markets must be developed for hand-made material. And owing to the tiring 'sameness' of standardized articles, there does exist a market for the hand-made product. The production and use of articles over a period of time by non-industrial means is usually correlated with a long tradition of design and pattern. These may still have clear implications of heraldry or of religion for the local group or their meanings may have been lost in the course of time.

A few generations ago such objects originating in exotic areas of the world were looked upon as mere curios which travellers brought home as evidence of their voyages. Today, however, there is a growing realization of their unique aspects. They are no longer considered as 'souvenirs' but are purchased for their intrinsic aesthetic qualities. They have become luxury goods, desired by those individuals who, possessing a higher income, are willing to purchase articles which are different from the standardized and the mass produced, and which represent long, careful and traditional workmanship.

One of the best documented case histories of the resurrection of a handicraft product was the revival of pottery manufacture in the little American Indian pueblo of San Ildefonso. San Ildefonso is a pueblo of Tewa-speaking people, located twenty odd miles away from Santa Fé, New Mexico, in the south western United States of America. In common with other pueblo Indian cultures its

(1) A commonly used definition is "Acculturation comprehends those phenomena which result when groups of individuals having different cultures come into continuous first-hand contact, with subsequent changes in the original cultural patterns of either or both groups".

economy was originally based upon the cultivation of maize, squash and beans. This diet was supplemented with game, wild fruits and plants. Native American cotton was raised, blankets woven, and pottery made. Religion was centred on the fertility of crops, and considerable emphasis was placed upon ceremonies to ensure adequate rainfall.

The first Europeans to enter this area were Spaniards from Mexico who penetrated the south west during the 17th and 18th centuries, but their influence left the economy of the people relatively untouched. Wheat later became an important cereal and the horse, sheep, goat and donkey, and several fruit crops, including peaches and melons, were introduced. In recent years the arrival of settlers of Anglo-Saxon derivation and the introduction of modern industrial economy has imposed great changes on the culture. The great mail order houses, the improved transportation and proximity of stores in Santa Fé, have influenced the material economy considerably. Money economy, in particular, has affected the traditional pattern of mutual obligations based upon kinship structure, which once governed social behaviour.

Agriculture is still practised, but today the most important source of income is the sale of pottery which . . . "supplies families not only with a livelihood, but with a surplus over and above the necessities of life. It buys automobiles, furniture, radios and sends young men to college. Moreover pottery is creating a leisure group within the pueblo, and the sale of pottery is helping to focus the attention of the people on the value of the American dollar". (1)

This was not always true, and at the turn of the century this craft was steadily deteriorating. Most of the women did not bother to manufacture containers with the same skill and care as their mothers or grandmothers had done in the past. Metallic containers and other products were rapidly replacing the hand-made pottery. Some earthenware goods were still made by the older women, particularly for sale to tourists who liked the poorly made imitations of water pitchers, copies of rain gods and candlesticks. The economic status of the pueblo was then very poor. Their numbers had been depleted through disease and other factors and their agricultural lands were being encroached upon.

In 1907 Dr. E. L. Hewett, of the School of American Research, began a series of excavations in the ancient ruins of the Pajarito Plateau. All of the labourers he hired were from San Ildefonso and as the ruin excavated was traditionally their ancestral home they naturally were interested in the results of the excavation. The women of the pueblo, when visiting the camp, often held animated discussions among themselves about the pottery which was recovered from the excavations. This interest was recognized and the women known to be better potters were encouraged to improve their standards, and to return to the level of attainment of their ancestors.

Some examples of the old pottery were still in the pueblo, and further examples were obtained from other sources. After its establishment the Museum of New Mexico participated actively in encouraging the renaissance of the art. This was a long-term process since most of the women were not willing to take on the extra work of manufacturing better products, when for the most part tourists preferred the less expensive, poorly made items as souvenirs. However, the museum encouraged the rising standards by purchasing the best pieces and refusing to buy the poor ones. (2)

One of the outstanding potters, Maria Montoya Martinez, eventually created a new type of pottery, using matt black designs on a lustrous black background, which proved to be very popular. This was in 1921, fourteen years after Hewett's excavations on the Pajarito Plateau, and it is a type of pottery which is still in constant and high demand. Today, all pottery is made for sale to tourists, and not for home use.

Several changes have occurred in the social fabric of life within this pueblo. As in many small cultural groups, the pattern of existence under aboriginal conditions was one of communal co-operation with definite patterns of mutual obligation in the sharing of labour. The change to a money economy was inevitable, but since pottery manufacture is traditionally women's work this

(1) Whitman, W., "The Pueblo Indians of San Ildefonso" In: Linton R. (editor), Acculturation in Seven North American Indian Tribes. New York, London, D. Appleton Century, 1940.

(2) During this period folk art did not have the popularity that it enjoys today, and the public had to be educated to appreciate the superior product.

has resulted in a change in their status. Pottery making has become the chief source of income and women have become increasingly prominent in the affairs of the pueblo. The shift to a money economy has also led to a breakdown of the pattern of mutual interdependence and these changes have imposed considerable strain on the social fabric. On the other hand, the gains far outweigh the difficulties which the pueblo would otherwise have had to face. The economic security which the people have achieved by the renaissance of native handicrafts has undoubtedly assisted their adjustment to urban industrial civilization. Furthermore, the recognition which they have received in terms of appreciation of their native craft has undoubtedly reinforced their morale.

Another excellent example of an attempt to restore a native craft is that of the Navaho rug. The pueblo of San Ildefonso is small (a total population of between 200 and 300) while the Navaho number nearly 60,000. Their numbers are increasing steadily and the reservation cannot support them adequately. The Navaho were once nomadic and according to early Spanish accounts were one of a number of Apache tribes. However, because of their location, within an arc formed by the Hopi, Zuni and Rio Grande pueblos, as well as their absorption of some pueblo refugees, they were much more affected by pueblo culture than other Apachean tribes. All authorities agree that the Navaho learned to weave from their pueblo neighbours and later learned to use wool from the Spaniards. In the course of time, however, they created a product which is uniquely theirs.

The Navaho wove their finest blankets during the first half of the 19th century. Originally their blanket, popular with other Indians and non-Indians alike, was designed to be used as a garment. Today this has become the Navaho 'rug' of commerce and is used either as a colourful wall hanging or as a rug. The standard of Navaho weaving had steadily deteriorated from its high point in the early 19th century and by the beginning of the 20th it was a rather shoddy product. A number of factors contributed to this: (1) the quality of wool had become progressively poorer - during the 'old' days the Navaho used to raid the flocks of the Spaniards and there was constant introduction of fresh Spanish Merino stock to their own flocks; after their 'pacification', raiding ceased and their stock deteriorated steadily; (2) machine spun yarns were introduced; (3) aniline dyes replaced the native dyes. Moreover, the social disorganization which results when there is too rapid loss of mores, so that transition to new value systems do not occur, leaves a people demoralized. The resultant social disorganization, frequently seen in increased drunkenness, breakdown of old family patterns, etc., cannot but help having an effect upon all the activities of a given society. The pride of craftsmanship and creativity of a native artisan or artist rapidly disappears when he feels that painstaking care becomes pointless, as much of what gave meaning to his work no longer exists. Such lowering of craft standards are symptoms of the stresses faced by the society of which he is a member. The problem of restoring or maintaining old craft traditions then becomes the problem of how to treat the society.

The coming of powdered, pre-packaged aniline dyes led to a tremendous increase in production because they were much more convenient and easy to use. Similarly, borders and patterns derived from prevailing tastes of White traders influenced the design. Colours were violent and at the same time were not 'fast'. Except for the fact that it was woven on a native loom, the Navaho 'rug' of the early 20th century was fast losing the qualities which set it apart from the commercial product. At the same time, because of the increase in population and the lack of sufficient grazing land, it was becoming increasingly important as a source of income. In 1913, the Secretary of the Board of Indian Commissioners estimated that the total sales from Navaho rugs reached half a million dollars and in 1923 \$750,000.

A number of people, including many traders, have taken an interest in the economic and social well-being of the Navaho. While museum techniques and collections were used to aid them in restoring the craft of blanket weaving, it was not as much a deliberate programme as was the case at San Ildefonso. One of the effective agencies was the National Association on Indian Affairs, a group of individuals interested in Indian welfare. In 1920 Miss Mary Wheelwright, secretary of the Boston branch of the Association reported that she had talked with Mr. McSparron of the Chinle Trading Post. Mr. McSparron said that it was becoming difficult to sell the Navaho rugs, and she agreed with him, adding:

"... the modern blankets were ugly and had lost their Indian quality of design. As to the colours that had gone almost entirely, as after attempting to sell blankets dyed with

commercial dyes the public preferred undyed wools . . . they tried to make their rugs attractive to the traders who were their only buyers by elaborating the designs suggested often by linoleum and other rugs they saw in the stores. "(1)

Miss Wheelwright then asked if any Indian still knew the use of the old vegetal dyes and when he replied that a few still did, she promised to buy the inevitable first failures if he encouraged them to produce some 'old style' blankets. Owing to the fact that such old blankets had been collector's items and were either in private hands or in museums, she first made patterns on brown wrapping paper and roughly sketched in the colours. These copies, in spite of their higher costs, were sold as rapidly as they were produced. The Navaho themselves were pleased with the return to their original designs and also embarked on a series of experiments to obtain different shades from mineral or vegetal sources.

Photographs of the old rugs were also made and distributed. Many of the women made trips to view the rugs in collections in museums and gained further appreciation of the work done by their grandmothers.

Today practically all the rugs or blankets are made for sale. The Navaho themselves prefer machine-made blankets for their own use. The production of blankets varies for a number of reasons. During times of economic plenty (e.g. when work is available in the oil fields) the production drops. Similarly if the price of raw wool is high, the Navaho prefer to sell the wool on the market rather than process it in the form of blankets. Unlike the pottery of San Ildefonso which is a major source of revenue, the Navaho hand woven product is not the primary economic resource of the people. Further, in terms of 'man' hours (woman hours) necessary for the production of a single blanket, returns from weaving are low. In this regard Amsden⁽²⁾ cites the experiment conducted by the Shiprock Trading Company in 1932. The Company hired one of their experienced weavers to come to the store and make a rug 2 1/2 by 5 feet in size. The market value of the rug, when completed, was \$12. They had paid the weaver 20 cents an hour and furnished the material - the cost of labour alone came to \$40.80.

The Navaho weaving industry therefore represents a type of handcraft product which is a marginal source of income. For the most part the rugs are woven during winter when there is more leisure. However, rugs are important in that they are a dependable source of supplementary income since there is a constant demand for them. The revived modern rug is no longer a stereotyped copy of the old, but has developed a new style faithful to the old traditions of craftsmanship. It commands higher prices and the weaver derives considerable satisfaction in turning out products of a high creative standard.

In summary, both San Ildefonso and the Navaho peoples had a long tradition in the production of handcraft articles. The revival of old skills and standards involved a number of interrelated problems.

- (1) The growth of industrialism has made handcraft products too expensive for local consumption. Furthermore, they may be associated with lower status, and though this may be a temporary phase, it does mean a loss of skills and a halt in the development of a traditional art form.
- (2) Since a given tradition is in a sense unique, it seems worth while to maintain it in the face of increasing standardization. However, in order to compensate for the loss of native markets with the coming of inexpensive manufactured articles, handcraft products usually have to be considered as luxury articles and new markets found for them.
- (3) Museums can assist such programmes in three principal ways:
 - (a) They are likely sources of examples of past products to be used to restore or maintain high standards (imitation may be necessary in the beginning if there

(1) C. A. Amsden, Navaho weaving, its technic and history. Santa Ana, California, Fine Arts Press, 1934.

(2) *Ibid.*, p. 236.

has been considerable loss of skill). Innovations can be encouraged if they continue to develop along the traditional patterns.

- (b) In setting up travelling exhibitions with both original articles or photographs and charts museum techniques of display can be used to instruct and to encourage productions of a high standard.
- (c) The purchasing policy of a museum can also stimulate production:
 - (i) Selection of outstanding products and the awarding of prizes can be used as incentives - the prestige factor is important.
 - (ii) Systematic purchases can also be used for a documentary history of the change and modifications which take place, thus further guiding the craftsman.

B. TECHNICAL ASSISTANCE PROBLEMS

The disparity in the living standards of different peoples throughout the world reflects to a great extent the difference in levels of production between industrialized and non-industrialized countries. Nor does the diffusion of traits from one culture to another proceed at an even flow. For humanitarian reasons modern medical practices may be introduced in an area characterized by high birth and high infantile death rates. Should the death rates be checked, the resultant growth in population will soon exceed the ability of the society to feed itself by its traditional means of food production. An important problem which confronts the world is the establishment of some sort of equilibrium in which control is exercised over the growth of population, and means of production are enabled to keep pace.

This implies a comprehensive educational programme among adults as well as non-adult members of different societies. It would mean a programme of education in the basic principles of contemporary science, appropriate techniques in agriculture, the development of new industry, as well as the development of public health and literacy. Exhibitions can be used to aid these programmes in a number of ways.

1. Livestock programmes

Although museum techniques have not been widely exploited to help solve such problems, it does not follow that they could not be used. There are few field workers to give instruction by direct demonstration, but their influence can be expanded by further exploitation of visual aids, particularly in the explanation of concepts which affect the values of a given culture. For example it would seem that a 'logical' explanation would be sufficient to cause a people to co-operate in a stock reduction programme in an over-stocked range. A well documented instance to illustrate the contrary, however, occurred when the Indian Service in the United States of America, imposed a stock reduction programme on the Navaho tribe. Overgrazing had contributed to rapid erosion and gulleying with a consequent drop in the water table. But the Navaho resented the stock reduction programme, which was imposed by fiat. They did not correlate the fact 'sheep' with 'erosion', but opposed the reduction programme on the grounds that the government was contributing to their poverty by taking away their principal means of support. (1)

An analogous situation exists among certain East African tribes, possessing a pastoral economy. Among these people large herds are a source of prestige and status. In recent years, however, with the growth in population, a stock reduction programme has become necessary. Furthermore, the range could be used much more efficiently were other types of cattle introduced for dairy or meat production. However, since the people's value system is not based on money economy such a change would require an intensive educational programme.

Specialists would be needed to determine the carrying power of the area, to investigate the possibilities of sowing particular types of grass, what other breeds of animals could be introduced to the best advantage, the grazing conditions, etc. But even among societies possessing an

(1) See Kluckhohn and Leighton, The Navaho. Cambridge, Harvard University Press; London, Cumberlege, 1946.

advanced technology, the ready acceptance of the findings of scientists is a relatively recent phenomenon. Among these tribes the failure of crops, increasing dessication of the pastures, poverty and other evils may be ascribed to witchcraft, failure to observe the proper rituals, the malignant attention of some deity, or to chance. Cause and effect correlations based upon pragmatic, scientific observations are not common unless one has been trained to form them. The problem is therefore an educational one, for experience has shown that corrective action applied by fiat leads either to resentment and misunderstanding or to further dependence. It is here that didactic exhibitions can be most useful.

In some areas where overgrazing is a problem, it may have been noticed that there was a change in vegetation when the land became eroded, that with the formation of gulleys water rushed off instead of soaking into the soil, without it being understood that the phenomena could be correlated with overgrazing. Linguistic difficulties increase the problem of communicating such concepts. Exhibitions, however, can show vegetational changes, and the effects of gulleying, etc., clearly illustrating the various factors which contribute to poor utilization of the pastures. These exhibits should present examples of the different types of plants, their range of preference for particular soils, and need of water and should show how overgrazing leads to erosion, how gulleying contributes to the lowering of the water table, etc.

Another series of exhibitions should demonstrate the remedial action suggested, explaining for example, the beneficial effects of stock reduction (if it is called for), the restoration of plant cover, the building of check dams to halt gulleying. They should be prepared in consultation with the specialist and each panel or case should illustrate one aspect of the problem, with a final clear synthesis relating the various factors for the prospective audience. Poverty stricken people suffering from malnutrition may be incapable of visualizing (without concrete examples) benefits which will result not in a day or two, but may follow only after several years of work and sacrifice.

Since co-operation and participation in such schemes as stock reduction would involve a change in the value system of a people who may prize large herds or flocks, other incentives and values must be substituted. Awards and prizes for good land management, for better animals (not for the most numerous), should be instituted - perhaps through the co-operation of the tribal leaders or tribal council - so that the individuals co-operating with the programme may obtain the desired status in a manner which is of ultimate benefit to the entire group.

2. Agriculture

The position is similar as regards agriculture. The recent growth of population in many areas has made increased demands upon agricultural resources. Here also the introduction of new technical methods in a non-industrial society presents a twofold problem - technical and social. The retention in the new culture of certain of the traditional elements can, nevertheless, make the transitional period easier.

A people introduced to a new, alien technology is sensitive about its own achievements and its own ways of doing things. Bad personal relationships will result if the instruction given assumes that the original technology is outmoded. One way of demonstrating interest in the original culture is to follow the example of the historical and agricultural museums. The people might be asked to take part in the educational programme by contributing examples of the agricultural equipment of preceding generations with descriptions of their use (or perhaps the local museums may have examples which could be borrowed). Exhibitions of such equipment will show that changes occurred in the past, just as they do today, albeit more slowly.

The functional relationship between the old implements, old patterns of work, and the new can also be shown. Many traditional ways of doing things are the result of slow, unconscious, empirical development. The people themselves may rationalize their technique from the standpoint of custom - saying that that was how it has always been done - or through religion. An agronomist will be able to cite important examples of native practice which would be worth continuing and which could be presented in a cause and effect relationship. In connexion with new methods and implements to be introduced by exhibitions emphasis should be given to the theme of continuity with the past.

Technological changes are much easier to deal with than cultural changes for societies have very different value systems. East of New Guinea, in the South Pacific, for instance, are Melanesian peoples who raise yams as their principal crops. Writing in 1922 Malinowski noted that the Trobriand Islanders

"... produce much more than they actually require, and in any average year they harvest perhaps twice as much as they can eat. Nowadays this surplus is exported by Europeans to feed plantation hands in other parts of New Guinea, in olden days it was simply allowed to rot. Again, they produce this surplus in a manner which entails much more work than is strictly necessary for obtaining the crops. Much time and labour is given to aesthetic purposes, to making gardens tidy, clean, clear of all debris; to building fine solid fences, to provide especially strong and big yam poles. All these things are to some extent required for the growth of the plant; but there can be no doubt that the natives push their conscientiousness far beyond the limit of the purely necessary."⁽¹⁾

Many other examples of value systems having a basis other than money economy are known.

The social system of the culture may be closely integrated with the system of land tenure. An excellent example of the stress undergone by a society having communal ownership of land when faced by the change to private ownership is found in the case of the Tanala.⁽²⁾ The Tanala are a tribe who live in the mountainous area of Madagascar, off the east coast of Africa. They practised slash-and-burn agriculture, with dry rice as the principal crop. The tribe is not a political unit, but the Tanala have a sense of relationship with all other Tanala. The largest, meaningful social and political group is the village, which is more or less economically and socially independent of other groups. Each village claimed rights to certain areas of land and within the village unit land was divided into several wards, each ward being worked by an extended family (a man, his wives, their children and their children's spouses and children).

Each year a new piece of land was cleared and planted and the old permitted to grow into forest again. There was a high degree of interdependence based upon mutual obligations which were determined by birth, sex, etc. Land was not individually owned. Cattle, while individually owned, were not important as a source of meat nor was their manure used as fertilizer. Cattle were killed only for sacrifices and funerals and their primary importance was the prestige they gave their owner.

When wet rice cultivation was introduced, several changes became necessary. In the first place, it was no longer necessary to be semi-nomadic since a paddy could be planted year after year. Secondly, the extended family was no longer an efficient unit. Land in the favoured valleys where paddy cultivation was possible was sought for in a mad scramble. The change resulted in the introduction of private land ownership, and the breakdown of the former village pattern of extended family units with their series of mutual obligations. The general insecurity and tension which accompanied the breakdown of the old patterns led to a considerable increase in crime, witchcraft, hysterical illness and other manifestations of anxiety.

Such histories of social disorganization in an acculturation situation have been recorded among many societies. Many American Indian tribes, Polynesian groups, and other small, closely knit societies have undergone the same tragic experience. The new cultural elements which were introduced developed in an alien tradition, and the old ways of doing things could not provide the people with the techniques to adjust themselves to a totally new situation. It is therefore not enough to introduce new technological skills. It is perhaps more important (and more difficult) to introduce or stimulate the development of new social techniques within the society so that it may adapt itself to the new situation,

A society which has been used to slow and gradual change over the years is faced by a considerable shock when exposed to the techniques of modern industrialized economy. If it feels itself to be at the mercy of implacable and unknowable forces it is likely to try to retreat from

(1) B. Malinowski, Argonauts of the Western Pacific. London, G. Routledge; New York, E. P. Dutton, 1922.

(2) See R. Linton, 'The Tanala of Madagascar'. In Kardiner, A., The individual and his society. New York, Columbia University Press, 1939.

reality, giving rise to various movements in which return to the 'good old days', the old and proper way of doing things, is advocated. Other examples of rejection may be seen in apathy, unwillingness, or a general increase in anxiety.

Many of these social ills can be avoided if the people understand what is being done and if they feel that they have some degree of control over events. It is extremely important then that the people should not be told what to do, but advised. The distinction between paternalism and guidance is not always easy to achieve. One of the key problems is that of communication, for the risk of paternalism is less if the people who are being instructed understand the process well enough to carry through on their own, rather than having to depend continuously upon the assistance of the technical group. It is in this area that exhibitions will be most useful.

Provocative displays can be made by using a mixture of implements in use, or models which show current practice and models which show the use of the new implements and techniques. Charts, photographs and diagrams can be used as supplementary explanatory material. Each of these different objects requires a different setting and method of display to avoid monotony. In terms of materials, much can be achieved with relatively limited means. Toy agricultural implements made by adult members of the society for their children can be used to illustrate current methods of the local group. Actual implements can also attract interest but it may not always be possible to exhibit a full-size tractor or a plough. However, many agricultural implement manufacturers make very detailed scale models of their products to be sold as toys (also to advertise their products), and these can and have been used to illustrate modern farming.

As in all exhibitions, additional knowledge can be disseminated obliquely. For example, a display of hybrid maize (Indian corn) or of new types of seed, etc., can be used to illustrate genetic principles. Other exhibits of agricultural practice can be used to illustrate the scientific principles which underlie good farm practice.

C. HEALTH PROGRAMMES

Although teams of technicians can rid a community of flies or inoculate a population with vaccines in order to lessen the incidence of disease, such short-term programmes, however efficacious, do not affect the cultural patterns of a people. The success of these programmes is based on the imposition of the advanced techniques of an alien science upon the local group. An entirely different aspect of public health is that of education envisaging the teaching of new concepts and change in the habits of the local group. This is a difficult and long-term process, for the habits of generations are not easily or quickly modified.

The pragmatic approach of modern science to the maintenance of health is a recent phenomenon. At one time people commonly thought of health in terms of the supernatural, and in many areas of the world, they still do. Illnesses may be ascribed to the 'evil eye', improper behaviour which has offended a deity, lack of proper ceremonial rituals, witchcraft, ghosts, etc. Where such is the belief, treatment is prescribed in terms of countering the malevolent threat of the supernatural. If medication is used, incantations are an integral part of its preparation and are believed to increase its potency. The 'medicine man' among the American Indians commonly treats the patient by 'removing' splinters, pebbles, or other objects which they believe caused the disease from the person who was ill. Drums, chanting, and the medicine man's 'power' exorcise the spirits or the witch who has caused the attack.

The traditional way of treating smallpox in western China, is to send a member of the family to the temple to burn incense before the gods, beseeching them to drive away the evil spirits which caused the disease; or the family may invite priests to come to the house to beat gongs and cymbals, burn incense and chant to drive away the evil spirits.⁽¹⁾

Educated members of a society which is undergoing acculturation may decry these beliefs as superstitious, but they may lack the inclination to live according to sound health principles. This is clearly borne out by the experience of a Unesco team sent to western China in 1949 to help develop a public health programme. Local artists were used to help produce a series of filmstrips, and they were educated enough to know that prayers and incantations were not sufficient to check the spread of epidemics or to maintain health, but -

(1) C. A. Nutting, 'Health Department Report'. In: The Healthy Village, Paris, Unesco, 1951.

"For instance, they all knew they should drink boiled water, that is not drink possibly contaminated water (practically all water in this land) but did they themselves always practise this rule? They knew that flies bred in filthy places and can carry germs, but did they take the necessary precautions so that flies did not bring them disease? Did they practise health habits and thus understand them so that they could put them into filmstrips which would help other people to practise them, not be just entertained looking at them? Health education to the point of getting people to practise it is a long slow process. Even in countries with far more advanced public health services than China's, the consistent practice of simple routine health habits is far behind what it should be."⁽¹⁾

A further characteristic of people undergoing acculturation is that, under its stress, the rise in the anxiety level of the society leads to many psychosomatic illnesses. The Navaho furnish an excellent example of this phenomenon; in recent years among them there has been a considerable increase in illnesses which are believed to have been caused by witchcraft. This has been marked by hysterical seizures, unexplained aches and pains, etc., all of which require the care of the native medicine man. Cures which are effected result from the fact that the social group rallies to support the afflicted individual and thus relieves his anxiety and tensions. In other societies under similar stresses different types of psychosomatic illnesses develop.

Cures for diseases may also result from native practices. Each successful cure regardless of the source of illness, tends, of course, to reinforce belief in the old ways of treating illness. Failures are usually explained by stating that the witch or ghost is too powerful for the practitioner to exorcise, just as a modern doctor may rationalize the failure of an operation or a treatment by saying that the patient was too far 'gone' or was unable to rally.

Any project of general education for healthful living should take all these factors into account. To be effective these programmes may have to attack assumptions of long standing, and replace local prejudice by enlightened understanding of the problems at issue. The teaching of ideas intended to stimulate the development of new habit patterns should adopt a concrete rather than a theoretical approach. In many countries during the past few years increasing use has been made of museum displays to disseminate knowledge concerning health, the spread and control of disease, the relationship of the individual to his environment. Such didactic displays have been shown in many science and natural history museums, and a few museums restrict themselves entirely to problems of health.

As in all effective displays, the goal must be clearly conceived. For exhibitions designed for public health programmes, there are a great many ready sources of material. Biological supply houses, for example, sell coloured slides which can be used in projections and mounted slides for viewing through a microscope are available - if the budget will allow for the expense. Some common parasites, such as the tapeworm, mounted in clear plastic make excellent display material as do casts and models of parasites giving a magnified view of the animal and its life cycle. If the programme of health education includes an attempt to explain the function of the different parts of the body, e.g. the story of the circulatory system, models of the heart, charts and drawings, may be purchased which would simplify the preparation of the exhibition.

Health museums provide another source of supply for exhibitions. Many of them make their own exhibition material - e.g. the 'story of human birth', in which the growth of the foetus and the birth process are clearly shown. Such models are useful in teaching prospective mothers pre- and post-natal care, as well as in developing a further understanding of the life cycle of man. In other words, in comparison with other areas, there is a great deal of ready made exhibition material available for health problems.

(1) Ibid., p. 35

CHAPTER II

THE EXHIBITION: SOME PRINCIPLES AND PRACTICAL SUGGESTIONS

Lack of subject matter is certainly not one of the problems faced by whoever wishes to prepare exhibitions for use in fundamental education programmes. In so far as fundamental education deals with basic problems experienced in backward areas by people faced with the need to adapt themselves, their economy, their society, their entire outlook upon life to a rapidly changing world without losing too much of value from the old, it is evident that the scope of material which can be used for exhibition purposes is nearly inexhaustible. The problem is not one of lack of ideas, but of choice as to which of the various subjects available is to be used.

Exhibitions should not be haphazard affairs. Instructional exhibits are most effective if there is a clearly defined theme. Having decided upon a theme, the next step is to plan an outline of what is to be told. Like all explanations, an instructional exhibit consists of three parts, (1) the introduction; (2) the main body of evidence; and (3) the summary and conclusions. Rough preliminary sketches should be made to illustrate the outline - they need not be finished and very probably will not be strictly adhered to once actual work on the exhibition has begun. It should be emphasized that the distinction between museum types of exhibitions and other visual aids used in educational programmes is that the former emphasize the use of three dimensional material and original objects. Explanatory texts, charts, photographs and diagrams are accessories to the exhibition and are not usually an important part of it.

The material to be used in the exhibition will then be selected on the basis of the outline and the preliminary sketches - some of it may be obtained locally, some may have to be borrowed or purchased elsewhere. One factor in the selection of the material to be shown is the size and weight of the object to be used. For fundamental education purposes, the exhibition should be mobile or potentially mobile in order to reach the widest audience.

LABELS

There are two schools of thought about the use of the label. One states that the object should speak for itself and the viewer should not have someone else's ideas imposed upon him - a tendency in the art museums; the other school thinks that the most important part of the exhibition is the labels and that the material on view only serves to illustrate the principles involved - a tendency in the science museums. Studies have been made of visitors' behaviour at museum exhibitions. It has been found that, even in literate societies, the majority of visitors do not bother to read the labels; most of them simply saunter through or just look at the objects on view. However, an interested minority finds that short labels are insufficient for their needs and so ask the staff for more detail.

A number of palliatives to this situation have been developed. One of the most common is the conducted tour, in which a member of the staff of trained volunteers takes groups around the museum or, if it is a single show case or exhibit, gives a short talk on it. These 'animated' labels can treat a given exhibition in greater detail than any card. Furthermore, questions may be put by the guide to the group in order to stress particular points, and questions which occur to the group may be answered in detail by the guide. Much has also been done to improve the quality of labels:

- (1) Attractive labels. On aesthetic grounds, a printed card may intrude upon an exhibition. However, rather than use none, attractive labels may be printed on special materials, or on cards or paper with a colour complementary to that of the background of the exhibit. In this way, they do not intrude upon the exhibit but become part of the visual effect and are also conveniently placed for the visitor desiring information.
- (2) 'Take away' labels have also proved to be successful. They are mimeographed sheets which discuss a particular exhibit. Interested visitors may help themselves to such sheets and take them home to study at leisure. An extension of this, for larger exhibitions, is the printed catalogue which is generally sold at a nominal sum to cover printing costs.

- (3) 'Gadget' labels. These are labels which require some action on the part of the visitor to function. They 'invite' the visitor to use them by stimulating his curiosity. At their simplest, they may involve turning a crank in order to see a new bit of information come into view. They may be semi-automatic, in which case a push-button device illuminates a sequence of labels simultaneously with the appropriate part of the exhibit. Various projection devices, such as automatic slide projectors, may also be used.

How to Write Labels: Labels are usually written in journalistic style: an eye-catching heading or title for a given portion of the exhibit in large sized letters, then a fuller label in small letters (subtitle) and the body of the explanation set out - from 20 to 30 words to a maximum of about 150-175. Labels longer than this are rarely read.

Printing Labels: The title of the exhibition may be painted by hand if someone skilled is available. Copies can be made in a suitable style of printing and then traced and painted. In many countries, pre-cut pasteboard letters may be purchased from art supply stores. The letters can be painted in different colours, and, if desired, metal can be imitated by painting them over with bronze, aluminium or copper 'paints' made of metallic powder suspended in lacquer. Smaller letters for sub-headings with an adhesive backing like postage stamps, may also be purchased in various colours.

Labels may also be typewritten and black is usually the most legible colour. Printed labels are most satisfactory from the point of view of legibility and general attractiveness, but they are much more expensive to use.

SMALL PICTORIAL EXHIBITS

Equipment

Implements: Knife (exacto or other similar types of knives with interchangeable blades are useful); ruler; iron (for dry thermo-plastic adhesives); cross-cut saw.

Supplies: Poster board, double weight Bristol board, beaver board (in ascending order of durability); masonite (pressed wood) and plywood for exhibits of greater permanence.

Adhesives: Liquid: rubber for non-permanent exhibits in which the photographs are to be used again; library paste (flour pastes in general); polyvinyl resin glues. Dry: photographic dry mounting tissue, adhesive tape.

Pictorial material generally needs to be mounted, either on some pasteboard backing or on some more durable material. Pasteboard products will be sufficient if the exhibit is not to be used over a long period of time and if the general size is not too large. Tempered masonite or plywood is preferable for equipment to be used for a longer period or destined to undergo hard wear. If the exhibit is intended for circulation among a number of different communities or institutions, it is best to use one standard size to facilitate packing and shipping.

Background Colour

Poster board, if available, is convenient to use because it can be purchased in a number of different colours and textures. Beaver board, masonite and plywood can be painted over. Many museums now use latex water paints, because they are comparatively easy to handle, brushes or rollers can be cleaned with water before the paint dries, and, once dry, the paint is waterproof. Furthermore, in the case of the more permanent materials, the likelihood is that they will be used again for other exhibitions and then a fresh coat of paint can be easily brushed or rolled over the original.

Natural finishes can be very pleasing. In many countries plywood can be purchased with a veneer of birch, maple, Philippine mahogany (luan), gum wood, etc. If such fine woods are used, a clear lacquer finish is all that is necessary. However the hard wood veneers are much more expensive than ordinary pine-faced plywood, and they may be unavailable locally. If one

is forced to use inexpensive plywood or cheap grades of lumber, other expedients may be tried. Locally made textiles such as mats, cloth or blankets, can be employed to cover the surface of the wood and furnish a background with a pleasing texture. Fishing nets, for example, may be used as drapes for exhibitions on fishing and allied crafts.

If the local textiles are not appropriate for the particular theme of the exhibition, inexpensive material, like burlap, may be used to cover the wood. When burlap is used, glue is usually applied to the board or plywood to be covered. The burlap is then stapled or tacked in place at the top of the board and stretched smoothly over the glue covered surface. A hard rubber roller, a rolling pin or a bottle may be used to press the cloth tight against the board and remove air pockets. The edges of the cloth are then tacked or stapled down, and can be masked by covering them with strips of wood. After the glue has dried, the burlapped surface can be brushed or rolled with paint.

Colours: Various shades of grey are the best colours for a background. Its neutral tones do not generally detract from the object on view. Flat black strips or pastel shades may be used in part of the background if it is felt that grey alone would be too monotonous. The use of warmer colours - the so-called 'decorator' colours - is becoming much more common. They involve more risks, as they may distract attention from the objects on view. Skilfully used however, they help to create moods which heighten the effects of the objects on exhibition.

Mounting Objects on Panels:

Small objects may be conveniently mounted on panels. One of the easiest ways to do this is to use perforated masonite or hard board (pegboard) in which holes are drilled an inch apart. If this is not obtainable, ordinary tempered masonite can be used with holes drilled as needed. A wide range of inexpensive hangers may be purchased which are designed to be used with this material. They are made in various sizes and shapes to handle various types of small objects. Such perforated sheets may be cut into free form shapes and mounted against a panel, a wall or within a case, or made into small standard size panels which can be framed for added rigidity (Fig. 1 - various types of joints used in making frames). Small panels, 2 x 3 feet, may be made from this material using loose pin butt hinges to form screens of two or more units.

Larger Panels: Larger panels and cases require a small carpentry shop. If powered tools can be used, a circular saw of the Tilting Arbour type would be extremely useful. A great deal of thought has been devoted to the design of panels. This is particularly true today as increasing importance is given to the use of flexible floor plans. In museums where this practice is followed, collapsible panels are used; they can be moved about for each succeeding exhibition in order to set off the objects on view to the best advantage. One version, the 'pogo' panel, which is used by the Yale Art Gallery (Yale University, New Haven, Connecticut), has panels mounted on poles containing powerful springs. When set vertically in place, the springs press the poles against the ceiling and the floor and thus hold the panel rigid.

Free standing panels are frequently used for temporary or travelling exhibitions. This type of panel depends upon the use of keyhole shaped slots into which notched pegs can be fitted. At its simplest, a large roundhead screw can be used as the peg. The face plate of a keyhole can be used for the other element. The head of the screw should be small enough to fit into the circular part of the keyhole and large enough to hold in the slit part. The hangers used to fasten the side supports of wooden beds to the head board can also be used for this purpose (Fig. 2).

These panels may be mounted in series on square posts with panels set at right angles for stability. Other adaptations include the use of A-shaped stands for free standing panels. The keyhole slots may be set either in the middle of the stands (in which case the panels can only be mounted in a straight line) or to the side so that the panels can be mounted in staggered series as well as in a straight line (Figs. 3 and 4).

The panel itself should be as light as possible and hollow construction is used for larger panels. In such a design, 'one-side good' plywood can be purchased; it is much less expensive than plywood having first quality veneers on both surfaces.

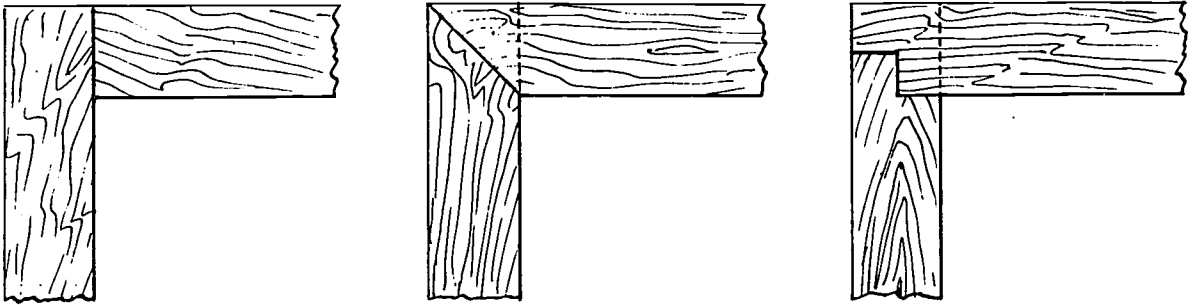

FIGURE 1

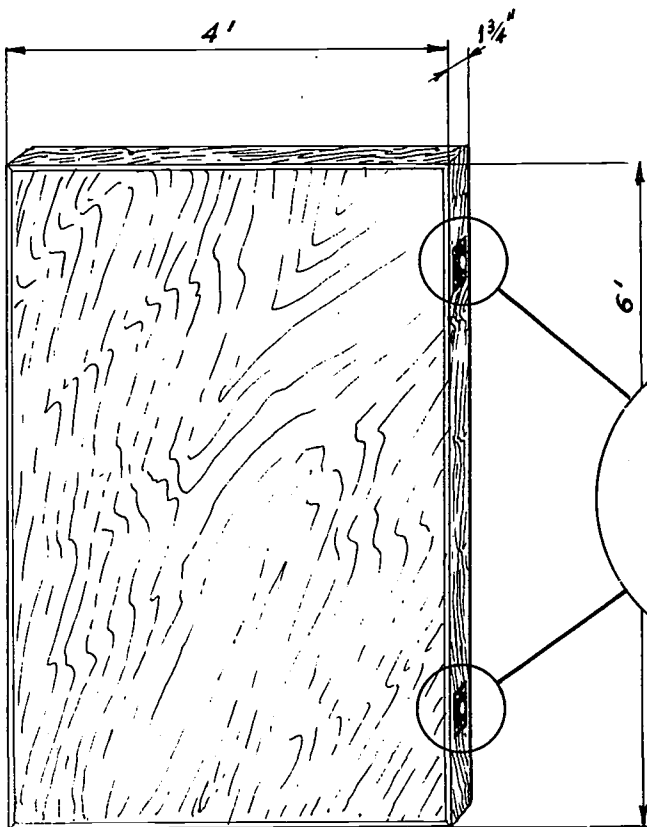
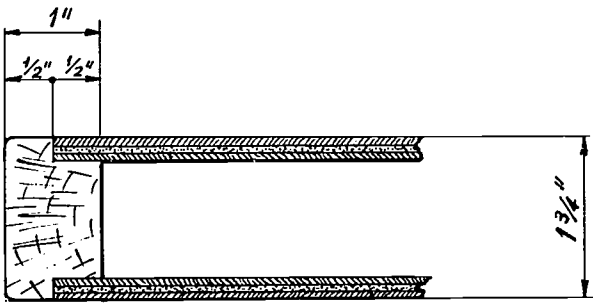
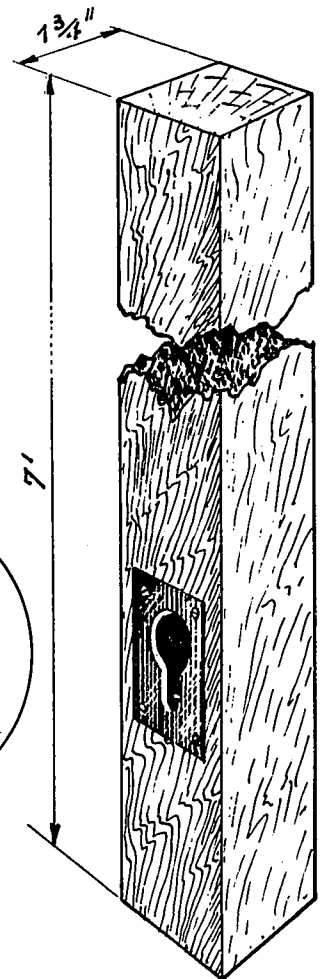

FIGURE 2



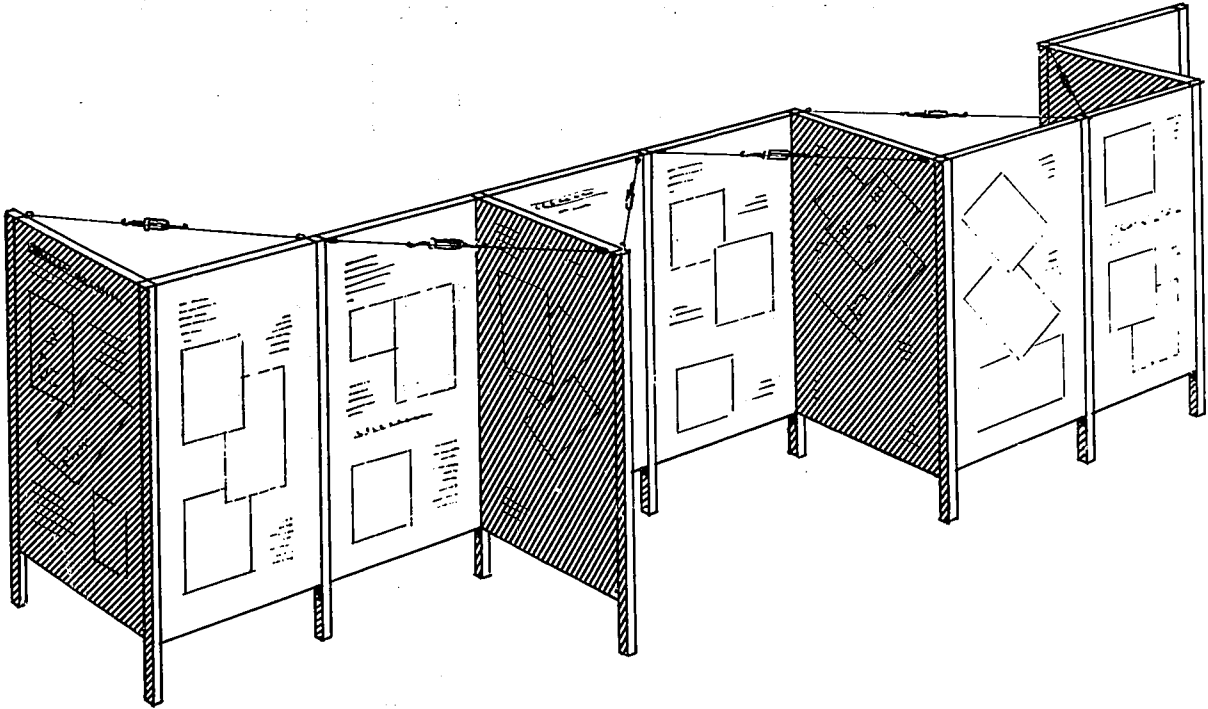

FIGURE 3

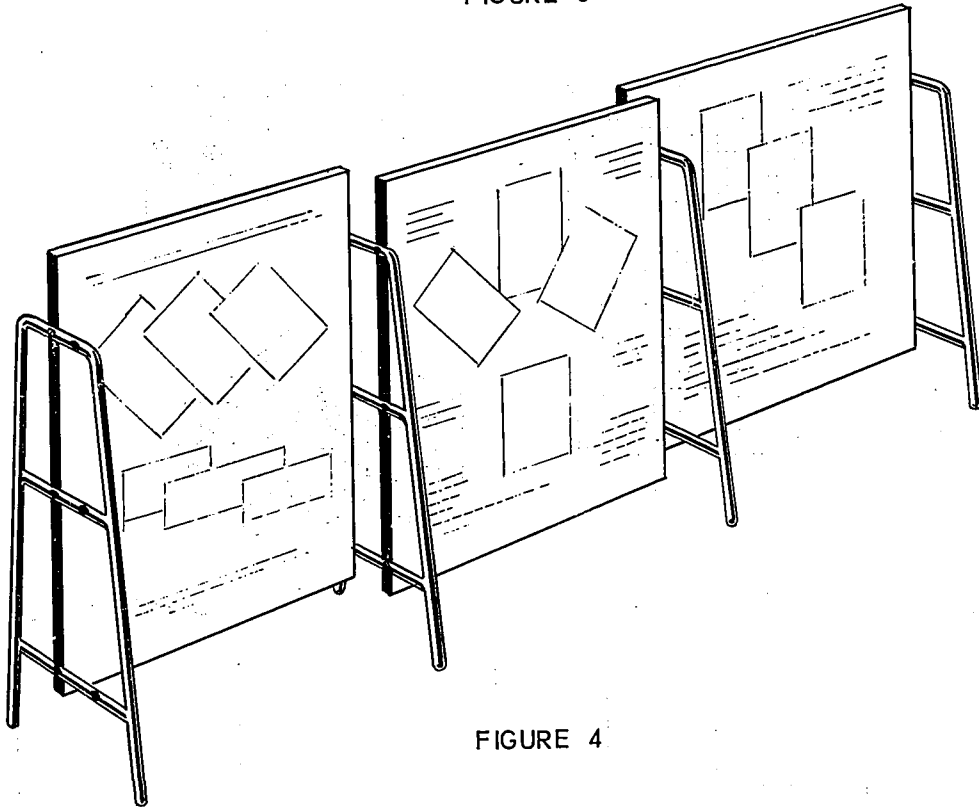

FIGURE 4

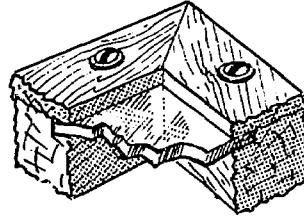
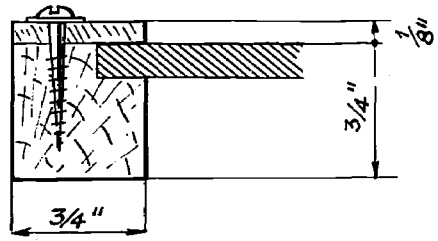
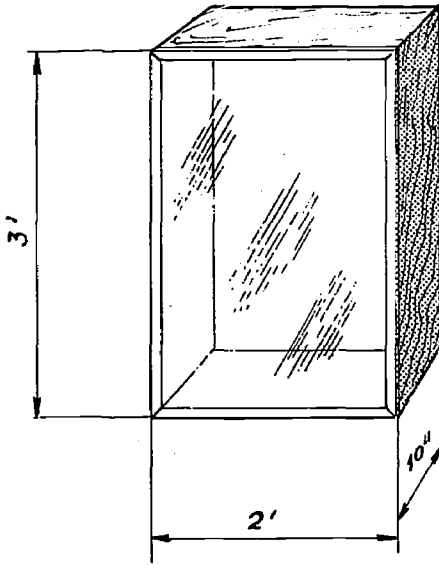

FIGURE 5

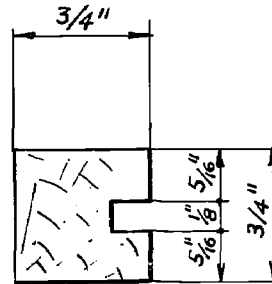
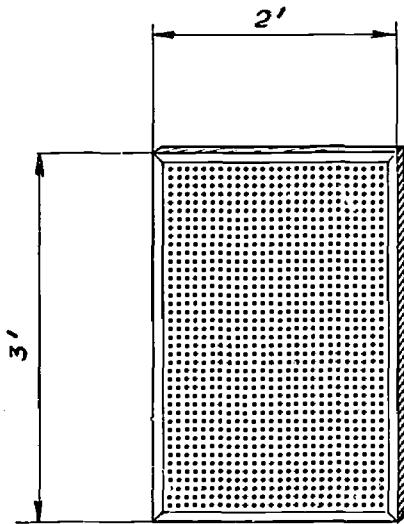
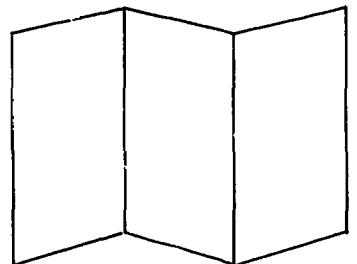
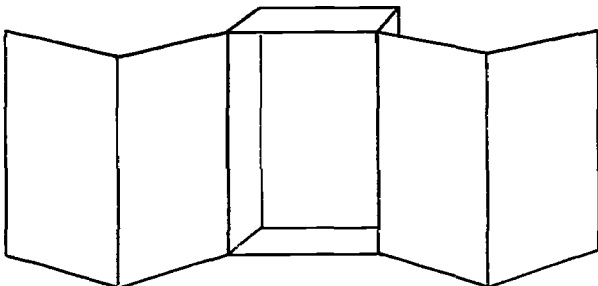
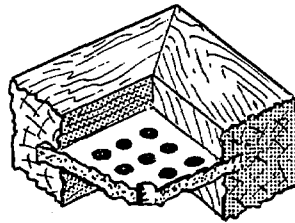

FIGURE 6



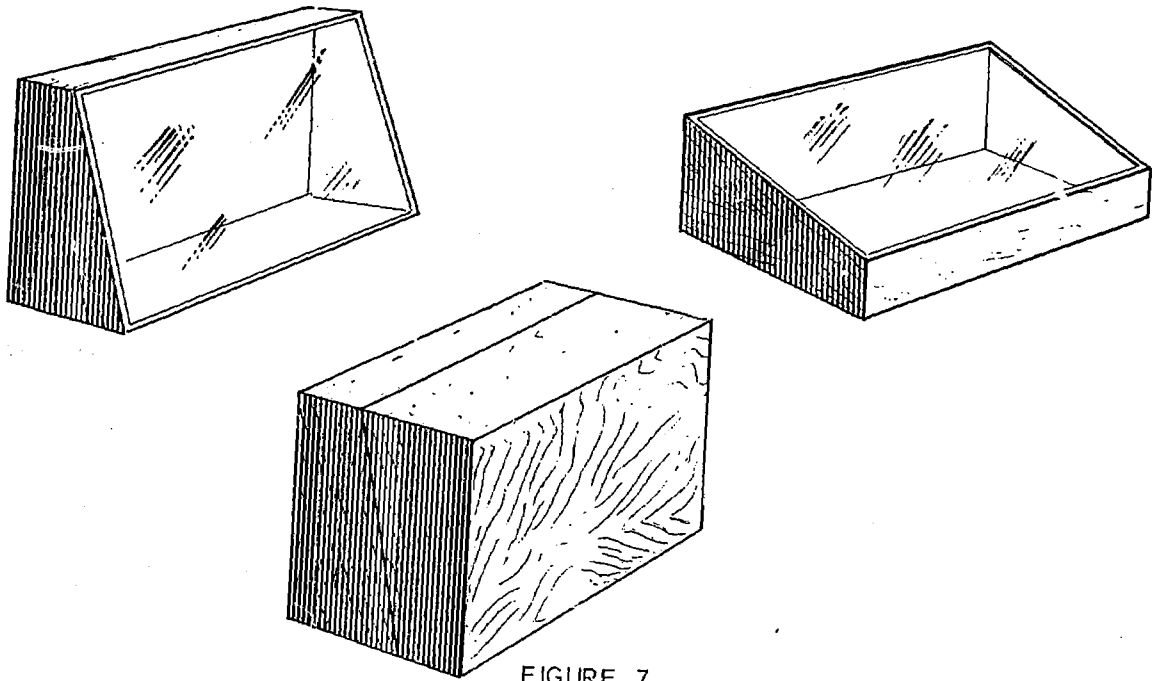

FIGURE 7

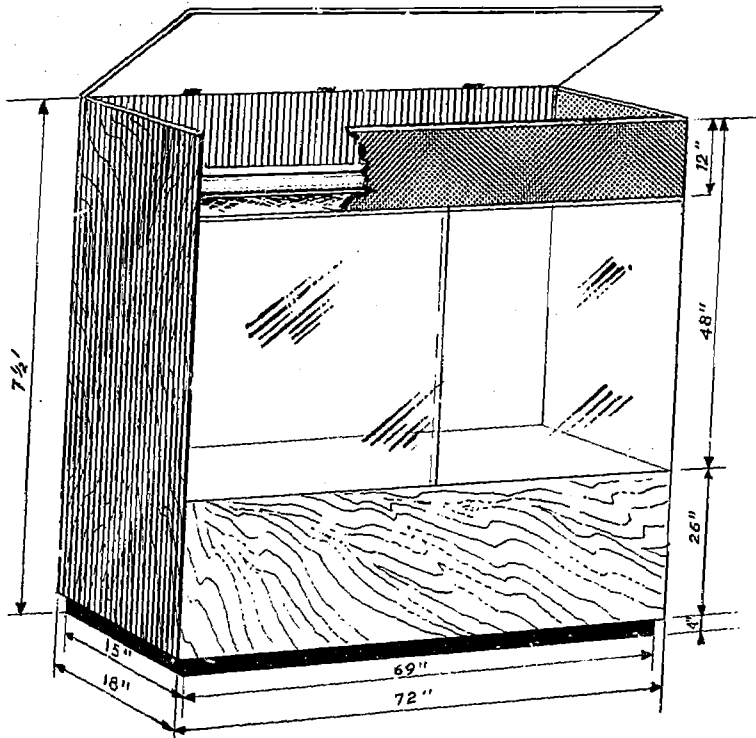

FIGURE 8

Protecting the Object on Exhibition

The ideal situation in exhibitions is to allow the visitors to handle the objects on view as well as to look at them. Tactile examination is theoretically preferable, but frequently not desirable due to the danger of breakage, damage or theft. In many museums, particularly for temporary exhibitions, barriers are set up to permit visual examination of objects, without the necessity of building expensive cases. A row of potted plants and vines or a raised platform suggest limits which the visitor should not cross. Rows of heavy carpet yarn suspended from a bar may be set in front of an exhibit as an attractive barrier. Fences may also be used for such purposes.

Cases for Travelling Exhibitions

It is frequently advisable to place material on exhibition within cases, so that it may be viewed but not handled. These cases may be quite small, simple rectangular boxes, or they may be fairly large. The limits of size depend primarily upon the transport available.

Such cases are intended to protect the material, to provide simpler means of transportation and to present the material as attractively as possible. With these three goals in mind, a number of different types of case has been designed by various museums. Some types have been developed in co-operation with commercial firms, while others are the products of museum workshops.

A simple box like travelling case can be built, using a framed glass cover (Fig. 5). Panels, which can be used as folding screens, may be used with such cases (Fig.6). Some museums have made use of small cases (suitcase exhibits) while others have built larger ones which require a van to move them from place to place.

Glass is commonly used as the transparent element of the case. It is generally inexpensive (double strength window glass is satisfactory for all but the larger cases) and easy to replace. It is also fairly simple to clean. Plexiglass has several advantages over glass, in that it is less subject to breakage and is much lighter in weight. Its disadvantages are its cost and maintenance, as it is easily scratched and becomes frosted in time. Small scratches may be removed by polishing the surface with a fine abrasive, but the constant maintenance required has usually led museums to prefer glass.

Large Cases

At headquarters, there will usually be more permanent exhibitions. Here, collapsible panels may still be used, particularly if a certain proportion of the exhibits consists of temporary ones which will be ultimately sent on tour. However, for convenience' sake, more permanent cases will probably be built. Even here, 'permanence' may be a relative factor, for what may seem suitable for current needs may be outmoded or outgrown later. Many museums in the United States of America are making increasing use of prefabricated units (like unistrut) which consist of steel sections and quick locking nuts and bolts to build cases which have the strength of permanent construction and yet are flexible enough for future changes which might be dictated by modifications of the building, shifting of exhibition space, etc.

Many museums also build their own cases and reduce costs by setting these cases against the walls. These inset cases need only one glassed side and are much easier to build. If large cases are built, plate glass must be used. Cases designed for the field should have glassed areas which begin about two and a half feet above floor level and continue to about six and a half feet above floor level (provision may be made for little children by putting a raised step or platform in front of the case) (Figs. 7 and 8).

Lighting

Most exhibitions in the field are probably intended for use in daylight only. The use of artificial light for exhibitions to be shown during the evening and night would depend upon local conditions. If gasoline pressure lamps are to be used, the exhibition should be examined under both daylight and the light of lanterns before it is sent out. The change in colour values which

results from shifting from one type of light to another may produce unexpected effects. If electricity is available, either from local power sources or from a portable generator, it should be noted that increasing use is being made of fluorescent lamps.

There are many advantages in the use of fluorescents. They consume much less electricity (a 20 watt tube gives as much light as a 60 watt incandescent bulb) and some of the newer types simulate daylight very closely. On the other hand, their performance is adversely affected by variations in current and they may not function too well under field conditions. It is therefore advisable to experiment with them before seriously considering their purchase. They would be particularly suitable for the permanent or fixed cases for exhibitions. They should be mounted as close as possible to the glass in order to minimize reflection.

Spots and floods help to emphasize special sections of an exhibition by calling attention to given objects or areas. They can be used to accentuate particular features of an object on view by emphasizing its dramatic aspects. Today, it is not necessary to purchase elaborate equipment as spot or flood bulbs may be purchased with built-in reflectors having a front lens element.

Mounting Flat Sheets

If photographs, graphs, charts or labels are to be used in the exhibit, various types of adhesives can be suggested according to the aims and purpose of the exhibition. If photographs are to be shown for a short period, the latex adhesives are satisfactory. They are clean, easy to apply, and at the end of the exhibition, the photograph can be peeled from its mount, the rubber picked off and the photograph placed in storage until needed again. However the latex adhesives become brittle and discoloured after a long lapse of time - furthermore the fact that the photograph can be easily peeled makes latex an unsuitable adhesive if the photograph is to be handled by people.

The cold water flour pastes or the standard library pastes are generally satisfactory but have a number of handicaps. They may be subject to attacks by insects or fungi and may cause blistering of pasteboard material.

If the objects to be mounted are not damaged by water (e. g. photographs) a wet adhesive may be used. The State Historical Society of Wisconsin uses the following procedure, based upon the polyvinyl resin glues obtainable in most countries under various trade names, to mount single weight glossy photographs on masonite. The place where the photograph is to be mounted is outlined and the glue applied with a brush in an even coating. The thoroughly dampened photograph is then placed on the paste covered area, covered with wax paper and rolled flat with a hard rubber roller. The wax paper is then removed, and the surplus glue wiped off with a damp cloth. This leaves a thin coating of the glue on the photograph, which dries to form a flexible, transparent, non-glare coating. This method can be used to mount photographs directly on panels or sheets of masonite which can be sawn, trimmed to size and subsequently mounted on larger panels or inside cases.

If the material to be mounted or the backing is adversely affected by moisture a number of dry, thermo-plastic adhesives may be used. The thermo-plastic adhesive is trimmed with its margins about 1/4 inch wider than the material to be mounted. It is then tacked in place by pressing it with a hot iron (about 300 - 350° F.) against the material to be mounted. Once the adhesive is fastened, it is trimmed down to its final size (if the object to be mounted is made of paper, it is convenient to trim both it and the adhesive together). The protective sheet is then removed and the object is ironed down against the backing. If metal is being mounted, pressure, as well as heat, should be applied for a few minutes.

Besides the foregoing adhesives, pressure sensitive adhesives exist. The makers of 'Scotch Tape' also sell Scotch Brand Double Coated Pressure Sensitive Tape. In use the protective masking is removed from one side of the tape which is then pressed against the object to be mounted (a photograph, label, cut-out letter for a title, etc.). The second protective coating is next removed and the material or object pressed against the backing.

Another frequent method for hanging small objects is to take common hairpins, bend the legs back to form hooks and insert them into squares of gauze. The gauze is then wetted with acetate cement, pressed on to the back of the object to be mounted, and dried. The loop of the hairpin can then be used to hang the object to a small brad, hook or nail.

Fine, black lacquered wire can also be used to fasten small objects to cases. The wire is unobtrusive and it can be fastened to staples or to small eye bolts mounted behind the specimen.

Heavier objects should be mounted on a shelf or a ring mount.

Many objects on exhibition can be shown to better advantage if placed upon pedestals either within cases or, for larger objects, out in the open. A tin can, stripped of its paper label and painted a suitable colour, makes a convenient cylindrical pedestal for a small object. Two by four, or 4 x 4 inch lumber, cut to suitable lengths, can also be used for the same purpose. Collapsible pedestals for travelling exhibitions of larger objects to be shown in the open can also be used.

Within cases, a few objects can sometimes be suspended rather than fastened to the back of the case or placed on the floor. Copper wire or black nylon string (nylon fishing line is convenient and strong) may be used for this purpose. On the same principle, a dowel to which material can be fastened may be set vertically in the case.

TRAFFIC PATTERN

An exhibition may vary from a series of small posters to illustrate a particular problem to a few cases of objects for demonstration purposes; or it may be a comprehensive exhibition employing both two and three dimensional material. Some attention should be paid to the presentation of the material to the audience. Having assembled the exhibition, the next step is to so arrange it that the audience views it in the sequence intended. For the most part a simple traffic pattern should be sufficient, with due regard given to the habits of the group for whom the show is designed.⁽¹⁾

Audience reaction varies with the circumstances and the use of an exhibition. Exhibitions may serve to introduce new material and concepts to a group, on the understanding that, as the course of instruction proceeds, details would be handled in the ordinary class or demonstration. Experience with different groups who visit museums has shown, however, that the groups or individuals who derive most value from visiting exhibitions are those who have had prior preparation or instruction. Material which was presented to them in abstract terms, in books or even in demonstration, tended to remain unassimilated. The length of the course of instruction would tend to lead to a collection of discrete items of knowledge lacking a systematic pattern. The exhibition would compress the time interval and make it easier to understand completely the new concepts which the fundamental education programme is introducing.

An audience which has received prior instruction can participate in question and answer group sessions with the specialist and can also gain a great deal from individual visits in which the material can be studied at leisure.

If exhibitions become widely used, particularly travelling exhibitions, circuits may be planned so that exhibitions can be moved from place to place along routes which minimize transport costs. The aid of local groups or individuals may frequently be obtained. Interested leaders of the community may assist in presenting the exhibition - they can be taken on special tours of instruction and can then act as guides for their fellow citizens (at first, under supervision). In so doing (as is proved by the experience of everyone who has done any teaching) these individuals will gain by absorbing new material in greater detail than they would do as students.

(1) To illustrate this, in the United States of America and many European countries one habitually drives on the right-hand side of the road and when coming to a roundabout naturally goes in an anti-clockwise direction. This has become so much a habit pattern that museum traffic patterns are usually planned to take advantage of this. In the United Kingdom, on the other hand, traffic keeps to the left and circles are normally made in a clockwise direction, with resultant consequences on unconscious traffic flow there.

CHAPTER III

THE COLLECTIONS

The fundamental education unit which has decided to use three dimensional material for exhibitions will, in due course, accumulate a fairly wide collection of objects. It is extremely easy to gather a large number of different kinds of material quickly, and indiscriminate gathering will rapidly result in an overflow exceeding storage capacity. While to a certain extent it is true that museums are the 'attics' of civilization in which the bric-à-brac and other outworn artifacts of man's material culture are stored, there is a wide difference between a cluttered assembly of odds and ends and systematic, significant collections. For fundamental education purposes, in which museum methods are a means and not an end in themselves, much greater discretion has to be exercised. The collections should be based upon restricted and clearly defined goals. The individual planning an exhibition will soon find that it is not too difficult to accumulate the desired material.

HOW COLLECTIONS ARE ACQUIRED

Purchase: Except for rare and unusual items, many museums lack budgets for purchases of material to be added to collections. More often than not, purchases made by a museum come under the heading of 'gifts', as individuals who are interested in the programme of a given museum can be asked to buy and donate a desired object. Purchase prizes, for example, organized to stimulate the development of a high standard of crafts production, may be done either on the budget of the museum or by gifts to the museum. Such purchases will enable the unit to build up a collection of the finest current production of the crafts in the region.

Gifts: Unsolicited gifts (other than financial!) can sometimes embarrass a museum. Gifts have considerable ego involvement on the part of donors. Usually, a donor would be content to see his gift placed on exhibition with a short credit line - 'Gift of Mr. John Doe, 3/12/54' - as compensation. However, donors frequently attempt to set conditions on their gifts, such as provisions for permanent display, or permanent retention of the gifts by the museum. Many museums have, in the past, accepted gifts hedged with a number of stringent restrictions in order to add rare or unusual items to their collections. However, these restrictions hamper the development of the museum and such gifts should be avoided, in principle, by all fundamental education units. This danger is so great that, a few years ago, the American Association of Museums passed a general resolution to the effect that all museums in the United States of America should refuse gifts with restrictions placed on them by the donor.

The museum should make it clear to the donor that it is free to use or dispose of the object as it pleases. Many museums use a standard receipt form, signed by the donor and a responsible official of the museum, which acknowledges the gift and states that the museum may use the gift as it sees fit. Such a form may be used by a fundamental education unit also. Unwanted gifts should be tactfully refused and the person who offered the gift may be encouraged to offer something which the museum or fundamental education unit really wants.

Loans: People will frequently try to use a museum as a storage warehouse and offer to loan material to it for exhibition purposes: such loans should be refused. Individuals may be asked to lend an item to the museum or unit for a temporary exhibition or a given purpose. A careful record should be kept of any loans made and they should be returned on the date specified.

Other museums or institutions in the neighbourhood may be approached for the same purpose.

Collecting by Staff: The main method of acquiring exhibition material is that of collection by the staff. In a fundamental education unit, this will probably be part of the secondary activities carried on by members in the field, who can keep an eye open for material suitable for exhibitions.

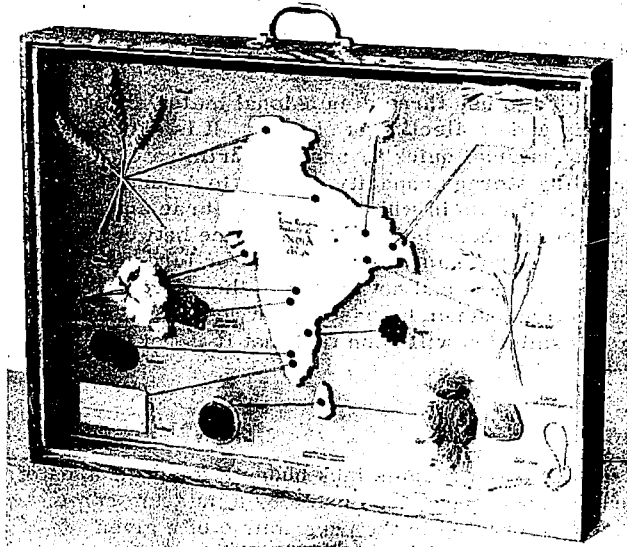

A simple «suit-case» type of exhibit requiring minimal maintenance in setting up exhibitions. (Leicester Museum, School Loan Collection, England).

It is tiring to view unbroken plane surfaces. Various devices can give depth, and change the visual focus. In this example narrow gauge wire was used to frame various types of two dimensional material. (Container Corporation of America, Chicago, Illinois, U.S., published in the *Manual for Travelling Exhibitions*).

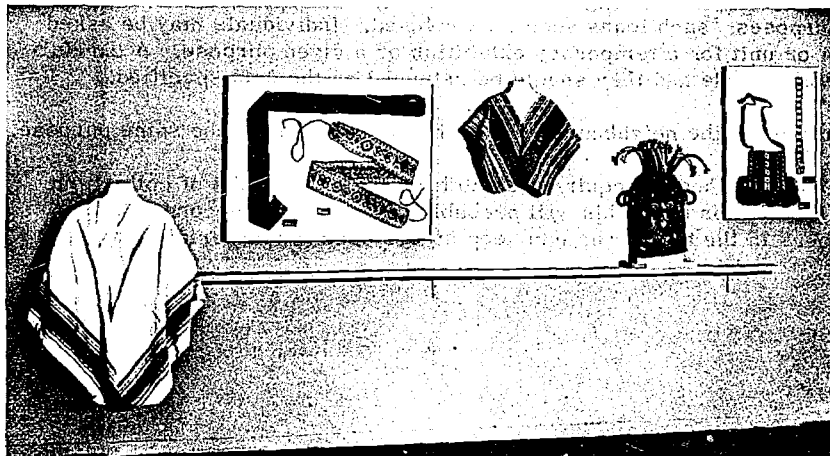
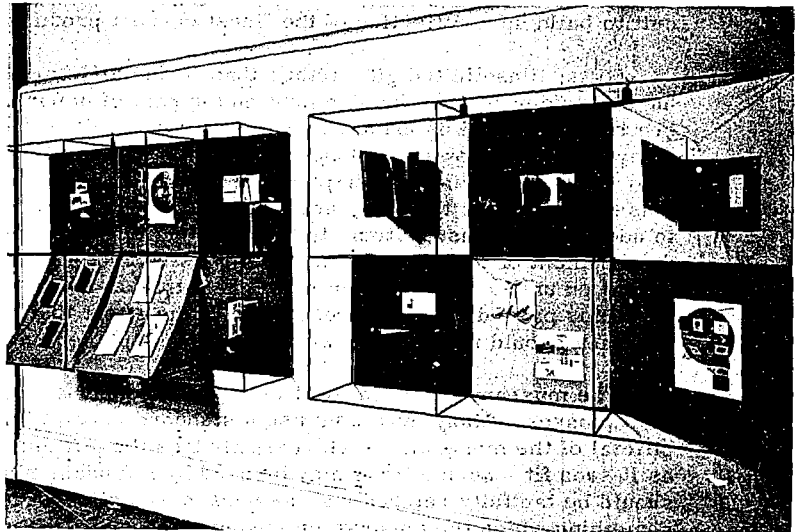

Effective presentation need not depend upon elaborate devices. This travelling exhibition of South American textiles uses simple panels to help unify the display and break up the background. (Museum of Modern Art, New York, N.Y., published in the *Manual of Travelling Exhibitions*).

Simple and effective presentation. Note the use of large dowels to support the outline map. The panels in the right background are joined together by eye-bolts through which dowels are slipped. The cases in the foreground are characterized by very clean lines. (Museo do Indio, Rio de Janeiro, Brazil. Published in *Museum*, Vol. 8, No. 1)

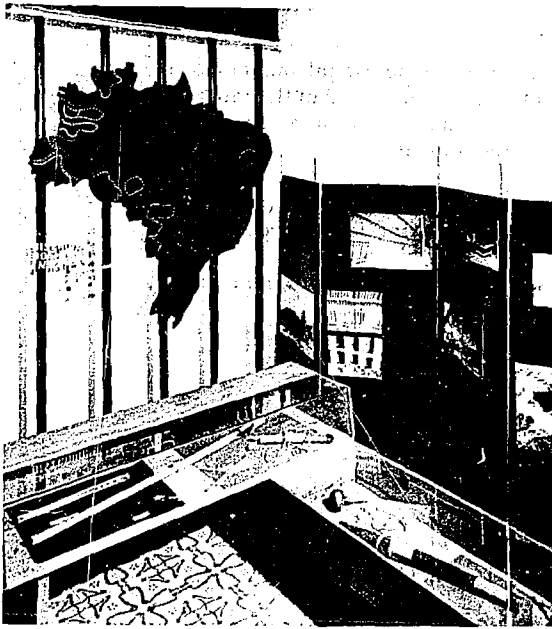

Ethnographic materials crowded together in show cases are extremely dull; intelligently displayed, they can be very exciting. This is an exhibition of Northwest Coast Indian and Eskimo masks. (Museum of International Folk Art, Santa Fe, New Mexico, USA).

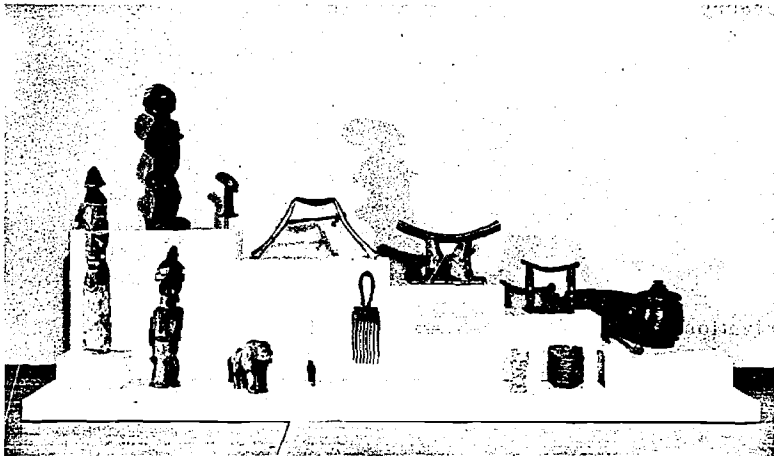
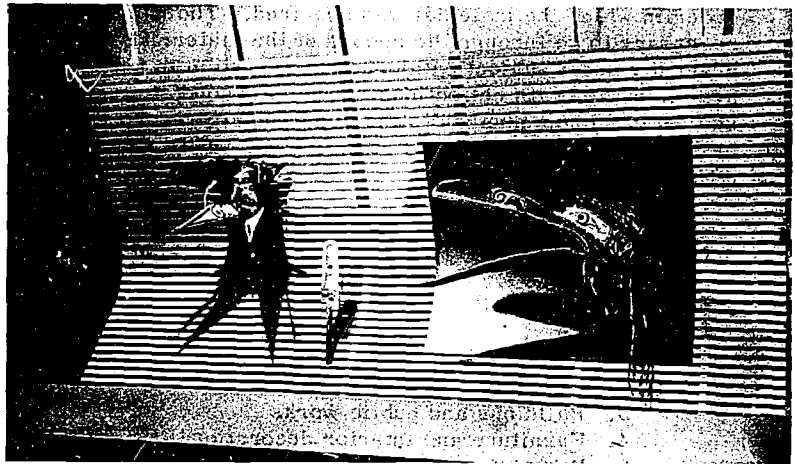

Simple light stands, such as the one shown here, can be made, by covering a wooden frame with beaver board or masonite. (Travelling exhibition of Carvings from East and West. The American Museum of Natural History, New York, N.Y., U.S.).

RECORDING THE COLLECTIONS

Records are essential. The value of a specimen to be used for educational purposes is much reduced if documentation concerning its origin, use, etc. is lacking. Furthermore, such data should be committed to some sort of written record in order that the information - which might otherwise be known only to a given individual - may be preserved.

The minimum record needed would probably be, for a small unit, a notebook (known in museum jargon as an 'accession book') in which the following information is recorded:

Accession number: The number given to the object as it is acquired in chronological order, 1, 2, 3, etc.

Date: (when object was acquired)

Object:

Date of its use:

Description of object:

Source: Purchase, Loan, Gift, Staff.

If the fundamental education unit is fairly large and the exhibition programme consequently more ambitious, it will soon be found that the accession book alone is a rather cumbersome and inefficient way of keeping records. The accession number merely records the chronological order in which the material was acquired. The number in itself is not useful if it becomes necessary to go through the record of the material available for a given exhibition. Museums generally use a subject catalogue filing system to keep track of the different material which is available within its collections. Thus a second step in the recording process is to assign a subject catalogue number to the object and to record it on a filing card which in turn can be filed by subject. This may sound complicated, but it pays in the long run. This number is usually affixed to the object as well.

In his Manual for Small Museums, Coleman has suggested the following classification scheme:

I. Material Culture

1. Foods
2. Clothing and personal adornment
3. Buildings and public works
4. Furniture and interior decoration
5. Domestic implements and utensils
6. Agriculture
7. Sanitation, medicine and surgery
8. Engineering and transportation
9. Industry
10. Commerce
11. Money and banking

II. Social Life

1. Customs and social structure
2. Organizations
3. Government
4. Education
5. Warfare and military organization
6. Individual life
7. Recreation
8. Music, poetry and drama

III. Religion and church

IV. Biography

For fundamental education units it would probably be useful to amend the list above by substituting Arts and crafts for I.9 Industry, and by placing Money and banking under I.10 Commerce. The following minimal information can be recorded on a catalogue card:

Catalogue No.

Utopia Fundamental Education Museum

Accession No.

Date of acquisition (day, month, year)

Description of object (measurements, sketches)

Approximate date of use _____

Source _____

People, tribe and/or region

Collected by _____

Gift, Purchase, Staff, Loan (circle the appropriate word, if loan from _____)

A hand plough might be recorded as follows: I.6/52, i.e. Material Culture, Agriculture, Item 52. The catalogue number should also be placed on the object. Several methods can be used for impermeable objects - one is to paint a small rectangle in white lacquer in an unobtrusive spot and write the number on it in Indian ink, and another is to use an engraving tool to place a permanent number on the object. Catalogue numbers may be written directly with Indian ink on textiles, leather, paper and material of a similar nature.

PREPARING SPECIMENS FOR EXHIBITION

Material placed on exhibition should be in presentable condition, i.e., reasonably clean and in a state of repair so that the viewer can easily see the function or purpose of the object on view. Most exhibitions prepared for fundamental education purposes would probably not use specimens (such as very old and rare manuscripts, textiles or other delicate material) which require a great deal of careful and expert treatment before they can be shown. Unless a large fundamental education unit has a museum and one or two staff members to work in it full time, it would probably be best to get such material prepared by sending it to a recognized museum laboratory specializing in such work.

On the other hand, an individual who is concerned with the preparation of exhibitions on a part-time basis could probably do the work necessary for objects in fairly good condition. A great deal can be done in the field without specialized equipment or material. As a general principle, the material placed on view should be as close to its original condition as possible, but excessive treatment or restoration should be avoided.

Textiles: Most cloth woven under native conditions and tinted with original dyes is colour fast. However, small scraps should be experimented with before cleaning. If the cloth is in good condition and not too dirty, it can be washed with a mild soap in cold or lukewarm water.

Be sure to rinse all the soap out of the material before drying it. If the cloth is dirty and greasy, and has proved to be colour fast, the material can be washed in a detergent solution made with cold or warm water. Once the material is dry, it can be pressed with a steam iron or ironed between damp cloths.

Dirty or greasy areas should be cleaned with the soiled area spread on a flat surface, wrong side up. An absorbent pad or blotting paper may be placed below the material to absorb excess moisture. Dampen a cloth pad with water, carbon tetrachloride or some other solvent, and sponge, using light brushing motions to spread the moisture irregularly into the surrounding fabric in order to prevent ring marks from forming. If the piece of material is small, the whole piece could probably be dipped in the liquid and then laid out to dry; this would avoid the risk of spotting the material.

If the cloth cannot be cleaned with either water or ordinary dry cleaning solutions, stains must be removed with chemicals.⁽¹⁾ Some commonly used ones are:

- (a) Javel water (this is neutralized with a solution of sodium thiosulphate - the 'hypo' of photographers).
- (b) Household ammonia (or ammonia water).
- (c) Potassium permanganate (neutralized with hydrogen peroxide for woollen materials and with lemon juice for linen, cotton or silken material).
- (d) Oxalic acid (neutralized with ammonia water).

The equipment needed includes a bowl and medicine dropper or a glass stirring rod, pads of cheese cloth or muslin and sheets of white blotting paper. When using chemical stain removers, the work should be done as rapidly as possible in order to prevent the chemical from attacking the fibres or the original dyes used.

In the first method, the stained portion of the cloth is stretched over the top of a bowl filled with clean water. A few drops of the solution to be used are then applied with a medicine dropper. The chemicals can be rinsed out quickly by dipping the material into the water. Another method is to place the stained portion over a pad or folded cloth and to apply the chemical with a glass rod.

In both systems it is best to use several different applications to permit slow and gradual bleaching so that the action can be arrested at the proper stage - practise on a piece of scrap cloth first. Neutralization of the bleaching agent should be thorough. This should be followed by rinsing in several changes of clear water.

The hazards of cleaning a material are:

- (a) The formation of rings - the deposit of the excess dressing of the fabric at the edge of the treated area.
- (b) Roughing, caused by excessive rubbing.
- (c) Excessive application of chemicals with consequent harm to the textile or dye.

If the textile is fairly fragile, it can be mounted for exhibition in several ways, one of the most common and easy of which is to place it between glass or plastic sheets. The edges of the sheets can then be taped together. The material may also be mounted on heavy linen cloth, a process which requires careful stitching of the material to the cloth. Small stitches are made, using thread which matches the material so that they are inconspicuous. If any cloth or textile material is to be stored, it should never be folded, but rolled round a pole or cardboard cylinder because creases weaken the fabric.

(1) A more detailed treatment is found in the National Park Field Manual for Museums, by Ned Burns, upon which this discussion is based.

Skins: Articles of raw hide may be subject to insect damage or to brittleness due to excessive dryness. Dampening with a wet sponge will restore flexibility. Clear petroleum jelly can be applied to the lower surface in order to reduce brittleness. Leather (skin which has been treated by tanning) should be kept in condition by neat's foot oil or petroleum jelly.

Wood: Wood exhibits may be subject to insect attacks, particularly by termites and the grubs of various beetles, and also by different kinds of fungi which cause wood rot. If the material is not painted, varnished or glued it can be treated by baking it in an oven at 130° F. for 12 hours, and then spraying or brushing it with clear cellulose acetate or the new clear synthetic finishes. If the wood cannot be treated with heat, it may be cleared of insect pests by dropping carbon tetrachloride solution in the openings left by the insects (care should be used, as carbon tetrachloride is an excellent solvent); badly infested wood should be treated by fumigation. After treatment the openings should be sealed off with cellulose acetate or clear plastic finish. Creosote is also effective, but it stains wood a dark brown.

Iron: For the most part, iron objects used for fundamental education exhibitions would not have greatly deteriorated. Cleaning with the use of a wire brush and steel wool should suffice. After the dirt and rust have been removed, the object can either be oiled or coated with clear lacquer or plastic finish.

Commercial polishes are available for most of the other metals. Tarnishing can be prevented by spraying or brushing the object with either clear lacquer, cellulose acetate or one of the synthetic plastic finishes.

CONCLUSIONS

THE USE OF EXHIBITIONS IN AN EDUCATIONAL PROGRAMME

Over the course of years, the rôle of exhibitions in museums has gradually been changing. Cluttered cases, filled with the accumulated material of indiscriminate collections, gave way to cases filled with ordered series which met the needs of specialists making comparative studies. Such collections still have their use for research purposes and for advanced studies. In recent years, however, collections of this type have been restricted to the serious student and are not designed for the problems of general education. Careful selection and presentation has led to exhibitions which are designed to teach and interest a wide public. However, specialization has inevitably occurred, and many museums have special departments and exhibitions designed for children (in which exhibits may be linked with the school curriculum), or other groups with specialized needs.

Education is, in part, the communication of learned techniques and traditions from one person or persons to others. The task with which fundamental education is faced is often the introduction of new knowledge and ways of doing things. It is, therefore, a challenging task and one in which a number of difficulties are inherent. Any field worker has, unavoidably, an ethnocentric outlook formed by his own culture. Values which he accepts unquestioningly may not and frequently do not exist in the culture of the people with whom he is working. The field worker should keep in mind that what he accepts as 'common sense' is not common to everyone. Bloomfield has pointed out that, in so far as individuals raised in Western European cultures are concerned: "much that masquerades as common sense is in fact highly sophisticated and derives, at no great distance, from the speculations of ancient and mediaeval philosophers." The members of the local group would also have their own brand of 'common sense', as this is clearly a cultural product.

The information to be conveyed should be presented in such a way that the people with whom the fundamental education programme is concerned can gain a clear concept of the data. Such concepts may run counter to the people's assumptions. Exhibitions may well prove to be one of the best ways of demonstrating the validity of new concepts. They should be based not upon the unconscious postulates underlying the thinking of the fundamental education specialist, but clearly understood and valid presumptions. Similarly, they should take into account the 'common sense' beliefs of the people for whom the exhibit is designed in order to demonstrate the non-rational basis of their beliefs, as contrasted with the more scientific approach.

SELECTED BIBLIOGRAPHY

- Amsden, Charles A. Navaho weaving, its technic and history. Santa Ana, California, Fine Arts Press, 1934. 261 p.
- Bergman, Helge. "Educational programmes of natural history museums in Europe/Les programmes éducatifs des musées d'histoire naturelle en Europe." Museum, Unesco, Paris, vol. V, no. 2, 1952, pp. 73-79.
- Burus, Ned J. See under: U.S. National Park Service.
- Cart, Germaine, Harrison, Molly, and Russell, Charles. Museums and young people. Paris, International Council of Museums, 1952. 131 p. Published also in French.
- Coleman, Laurence V. Manual for small museums. New York, G. P. Putnam, 1927. 395 p.
- Goetz, H. "Indian museums and publicity". Journal of Indian Museums, Bombay, July 1945, pp. 36-43.
- Godwin, Mabel W. "Museum educational facilities/Ressources éducatives des musées." Museum, Unesco, Paris, vol. VI, no. 4, 1953, pp. 220-227.
- Hatt, Robert T. "Educational programmes of natural history museums in the United States/Les programmes éducatifs des musées d'histoire naturelle aux Etats-Unis." Museum, Unesco, Paris, vol. V, no. 1, 1952, pp. 11-13.
- Jiménez, Alfonso y Melendez, Carlos. "La función de los museos en la educación" Revista de la Universidad de Costa Rica, San José, no. 8, diciembre 1952, pp. 103-115.
- Kluckhohn, Clyde and Leighton, Dorothea. The Navaho. Cambridge, Mass., Harvard University Press; London, G. Cumberlege, 1946. 258 p.
- Linton, Ralph. "The Tanala of Madagascar". In: Kardiner, Abram, The individual and his society. New York, Columbia University Press, 1939. 503 p. pp. 251-290.
- _____. ed. Acculturation in seven North American Indian tribes. New York, London, D. Appleton Century, 1940. 526 p.
- Malinowski, Bronislaw. Argonauts of the Western Pacific. London, G. Routledge; New York, E. P. Dutton, 1922. 527 p.
- Morley, Grace McC. "Installation of exhibitions for education/Présentation des expositions éducatives." Museum, Unesco, Paris, vol. V, no. 2, 1952, pp. 80-97.
- Osborn, Elodie C. Manual of travelling exhibitions. Paris, Unesco, 1953. 111 p. (Museums and Monuments - 5). Published also in French.
- Pernoud, Régine. "L'expérience pédagogique du Musée de l'histoire de France/An Educational Experiment by the Musée de l'histoire de France." Museum, Unesco, Paris, vol. V, no. 4, 1952, pp. 217-224.
- Rivière, Georges H. "The museum and adult education, a report". In: Unesco. Adult education, current trends and practices. Paris, 1950. 147 p. pp. 132-140. Also published in French and Italian.
- Sougy, P. et Avezard, J. "Une collection souhaitable: musée et lycée." Information scientifique, Paris, no. 2, mars/avril 1949, pp. 57-62.

Tuan, Janina. "Ethnographical and ethnological museums and the public/Le musée d'ethnographie et d'ethnologie et le public." Museum, Unesco, Paris, vol. II, no. 3, 1949, pp. 180-187.

Unesco. The healthy village. An experiment in visual education in West China. Paris, 1951. 119 p. (Monographs on Fundamental Education - V). Also published in French and Spanish.

Unesco. Preservation and development of indigenous arts, a report. Paris, 1950. 45 p. (Occasional Papers in Education - 8). Also published in French and Spanish.

Unesco. Some papers on the rôle of museums in education. Paris, 1952. 37 p. (Occasional Papers in Education - 13). Also published in French and Spanish.

U.S. National Park Service. Field manual for museums. by Ned J. Burns. Washington, D.C., U.S. Govt. Print. Off., 1941. 426 p.

Walters Art Gallery, Baltimore. Circulating exhibitions for city, county and State. Baltimore, 1953. 32 p. (Circular on Museum Education - 4).

Walters Art Gallery, Baltimore. Training teachers to use museums. Baltimore, 1952. 31 p. (Circular on Museum Education - 3).

Museum. Quarterly. Unesco, 19 Avenue Kléber, Paris 16e. Annual subscription: 1,000 francs; \$5.00; 21/-. Single issues: 300 francs; \$1.50; 6/-. Bilingual English and French.

PART II

MUSEUM TECHNIQUES IN FUNDAMENTAL EDUCATION:
THE MYSORE EXPERIMENTS

CHAPTER I

PLANNING THE EXHIBITION

From December 1953 to May 1955, in the rural district of Yelwal, Mysore, an experimental training scheme was held for specialists in fundamental education. The project, carried out by Unesco at the invitation of the Government of India and the Government of Mysore, offered training courses of nine months' duration to two groups of senior students - 38 in all from 20 countries.

Within a radius of 5 miles from the Yelwal Bungalow, a large house which served as the Unesco Training Centre, there were over 70 villages, in which could be found most of the problems that fundamental education has to face: a high rate of illiteracy, a heavy density of population, land hunger and fragmentation, shortage of grazing, deforestation, erosion and increasing barrenness of the soil, and widespread poverty. It was, in fact, an ideal practice area for the training scheme - a depressed area in a State noted for its progressive development policies.

The training scheme was experimental in two senses. It was itself an experiment in training; equally, training was given by experimental methods. It involved a large measure of actual experience in the villages and the group set itself a series of practical objectives to be pursued by teams and individuals.

One of these objectives chosen by the team which specialized in audio-visual education, was the construction of a museum exhibition unit, and three members of the team were assigned to this project. They brought to it a varied experience in the graphic and plastic arts, photography and radio.

The purpose of their experiment may be briefly summarized as follows:

To get practical training in the use of museum exhibitions for fundamental education and in the actual construction of an exhibition unit;

To build up an experimental unit on a suitable topic and to try it out on the villagers of the Yelwal area; and

To study the experiment in a wider context, considering how it could be adapted and applied to different environments.

A training technique, which had been tried with success in other experiments, was used in this project. First the members of the team, with the help of the staff, wrote a draft manual on the construction of an exhibition unit. This was, so to speak, the team's instructions to itself, written with more imagination than experience. The team then took the manual as its own guide and in four months of intermittent work attempted to construct the type of unit described. Finally the 'manual' itself was revised in the light of this experience.

A short quotation from the introductory section of this manual will perhaps help to establish the theoretical background of the experiment.

"It is the purpose of fundamental education to help people, who have not had access to formal schooling, to understand and solve their immediate problems by their own efforts. It is therefore often necessary to touch, simultaneously, the understanding and the emotions of groups of people who are entirely or largely illiterate and cannot be approached through the written word.

Many media of education have been used for this purpose, including films, filmstrips, posters, radio and sound recordings. Too often, however, they have given disappointing results, because they have been produced and used unsystematically or in isolation. It is, in fact, becoming more and more widely accepted that these media should be combined and concentrated systematically upon the chosen subject, if their educational impact is to be in proportion to their cost.

A museum or exhibition unit can combine these different educational media with others, such as models and actual objects, which can be touched and closely examined. In this way ideas and knowledge can be conveyed in a simple and forceful manner, which may well leave a lasting impression in the minds of illiterate people. Not only can the various media be systematically applied to a single topic, or a number of associated topics, but they may also be designed to appeal to special groups of people living under similar conditions. Perhaps most important of all, those who are interested can return again and again, when they wish, and absorb and reabsorb knowledge and ideas at their leisure and after personal thought and reflection."

Decision on the Type of Unit to be Built

The first problem which faced the Unesco training team was to decide on the type, size and cost of their exhibition. This problem was briefly touched upon in the draft manual:

"The nature of the unit must, of course, depend upon the site, or sites, in which it is to be used. Here at once a choice is presented - whether it is to be static - permanently installed in some suitable centre, where people gather - or mobile - capable of being transported from place to place and displayed for a few days in each. The second alternative has many advantages, but must add considerably to the difficulty and cost of its construction and maintenance."

Most writings on museums for fundamental education have assumed an idealized situation where mobile units, generally conceived as large motor trucks or trailers equipped for exhibition purposes, are based upon a well established, permanent museum. This arrangement, in theory, provides for the best technical services on the museographic side, but in the first place it is seldom likely to exist and in the second it offers no solution to the fundamental problem - how to construct, for remote rural areas, exhibitions which are:

Intelligible and interesting to largely uneducated and illiterate audiences.

Technically sound on the topics they present in all their local implications.

Co-ordinated with the broader programmes of fundamental education and community development into which they should fit.

It may, therefore, be more important that an exhibition unit for fundamental education should emanate from a centre equipped for educational experiments and for the production of educational materials, than that it should emanate from a properly equipped parent museum. The ideal of course is that it should be a product of both - the child of a true marriage between museography and fundamental education.

In Mysore the situation was typical - and far from ideal. No modern educational museum was known within many hundreds of miles. Communications were long and slow. Any piece of equipment ordered from Europe would take several months and much filling of forms to reach the Unesco Centre, and then might well arrive incomplete or damaged. So the Unesco training group, working against time in a temporary centre, had to use its own ingenuity and local resources. It therefore decided to construct a modest unit which could be set up in one room and would be capable of being remade in mobile form with a minimum of adaptation.

This decision was taken by the production team in consultation with the director and staff of the fundamental education training centre. It was, in fact, a joint decision of exhibition specialists and fundamental education specialists, and was the first step in the expanding programme of team work and co-ordinated activity which brought the exhibition to life.

Choice of Topic

It was suggested in the team's 'museum manual' that an exhibition unit for fundamental education should be focused upon a single important problem or topic - that "it should concentrate the various media employed upon conveying to those who see it, the essential scientific knowledge required for its solution."

The manual continued:

"The full impact of the unit will be lost if it attempts to deal with a subject that is too wide or with several subjects at once. Obviously in the selection of the topic or subject matter for the exhibition attention must be paid both to the 'felt needs' of the community and to its 'real needs', which may not always be identical. In fact such an exhibition unit may have a special value in converting a 'real need' into a 'felt need' - in calling popular attention to a problem which has not been appreciated as such in the past."

While the audio-visual team was discussing its plans for the exhibition, the social sciences team in the training group was making a number of studies in surrounding villages.

These basic surveys were regarded as a prerequisite to any activity in fundamental education, and were the subject of a separate manual written by the Unesco training group. In this manual the view was put forward that the initial basic survey should not only record conditions as they were - the problems and needs - in the community, but should also find out, through simple 'opinion study' techniques, what the people thought, felt and did about them. It was then suggested that individual problems, brought to light by the initial survey, should eventually be studied in greater depth, a process described as 'topic study'. In this process, the results of observation, and both expert and popular opinion should be analysed, so as to clarify the problem in all its relationships and to propose solutions. The selection of the topic for the exhibition was thus regarded as a function of a basic survey which would then be followed by a deeper study of the topic chosen. This systematic procedure was at first more honoured in the breach than the observance in the Mysore scheme, for the reason that the social science team's surveys were not complete at the time when the topic for the exhibition had to be chosen.

Experience proved, however, that basic survey and topic study are most important elements in the planning and production of all types of materials for fundamental education, and have a special importance in the preparation of an exhibition unit, which may deal rather intensively with a single subject from several different angles. So the team work and co-ordination involved in the exhibition project was further widened to involve the social science specialists in the group.

The topic which was eventually chosen for the exhibition unit, and for a number of other projects of the Unesco team, was Trees and the Soil. As in so many tropical areas of little rainfall, this represented a very serious problem in the Yelwal area. Vast stretches of hilltop land, which fifty years before had carried forests, were now denuded of trees and being rapidly reduced to wasteland by overgrazing and erosion. The problem was a very real one, and in a vague way the more intelligent villagers were aware of it; but they were not conscious of its complex origins or of the connexion between the indiscriminate cutting of timber and the loss of fertility of the land, changes of climate and more general degeneration of their village economy. The planting of trees on wastelands was, in the jargon of community development, a 'real need', and one which greatly exercised the minds of the State Forestry Department, but it was not a 'felt need' of the villagers. It was all the more interesting for the Unesco training group to see how far the modern media of mass education could make it so.

The museum manual, therefore, set the following objectives for the experimental exhibition unit:

"To convey to illiterate adults the general and scientific knowledge required to understand this problem in relation to the conditions of their particular area;

To motivate them to take the necessary action for its long-term solution."

Study of Topic

As the museum project developed the training group discovered that this task of producing educational materials, on a technical subject, to convey ideas to illiterate adults in an underdeveloped rural area, required concerted work between a variety of specialists - at least:

- A production specialist;
- A fundamental education specialist;
- A topic specialist;
- A social science specialist.

In fact each of these categories may include more than one person - or indeed a whole technical team - as was in large part the case in the experiment here described.

The production specialists were the three members of the audio-visual team already mentioned.

The director of the Unesco training scheme played the rôle of the fundamental education specialist, whose task was to co-ordinate the work of the group, to see that the educational purposes of the exhibition were established and pursued, and in particular to ensure that the technicalities of the topic were so interpreted that they would be interesting and intelligible to the future audience.

The functions of the social science specialist were carried, as already indicated, by the social science team in the training group. These functions were broadly to guide the selection of the topic and to study it with all its local implications, to study also the future audience and its opinions, interests and customs, as they related to the topic, and later to evaluate the reactions of this audience to the exhibition.

The topic specialists or technical advisers included a number of experts in forestry, botany and rural economy. The most eminent of them - the Chief Conservator of Forests of Mysore State and his Research Officer, and two Professors of Botany from the University of Mysore - were naturally only available for short consultations, but the Chief Conservator kindly attached to the Unesco group a local Forestry Officer as permanent topic specialist and adviser.

So the production specialists were reinforced for the planning of the exhibition into a flexible production group including also fundamental education specialists, social science specialists and topic specialists.

The first stage in the process was the study of the technical aspects of the subject. For this purpose the fundamental education specialist and the social science team prepared a five-page questionnaire, including 37 questions, on "Forestation in the Yelwal Area." This was sent to the Chief Conservator of Forests and his Research Officer, who after studying these questions, generously spent several hours discussing them with the whole Unesco group. Afterwards they accompanied the group in a field trip to examine deforested and eroded areas in the neighbourhood and to suggest how the problem could be overcome if the villagers could be informed of its gravity and induced to act together for its solution. These carefully prepared consultations, followed by discussions with specialists in botany and some reading of recommended books, enabled the production group to obtain a broad grasp of the subject from a technical angle.

Meanwhile the social science team, working on its village surveys, continued with an informal topic study, in order to find out what the villagers thought, knew and did about the problem. It has become a truism that any educational project should start from where the people are, but how seldom is any systematic effort made to find out just where that is.

The study of the subject did not of course end with this initial phase. Constantly, as the exhibit grew under the hands of the constructors, technical problems of botany, forestry and local economy would arise, demanding constant reference to the topic specialists and to the social scientists who could advise on its local implications.

Technical Planning

For the sake of clarity the various phases of the exhibition project are here described as distinct successive operations. In fact, however, they overlapped considerably. Technical planning of the exhibition was inevitably mixed up with the study of the topic, and the actual constructional stage was begun before plans were finalized; and in fact, the plans were modified as experiments with this or that gadget, or type of material, succeeded or failed.

Perhaps the simplest way of conveying an idea of the plan of the exhibition will be to quote extensively from the production team's manual.

"The exhibition unit is intended to be installed either in a suitable building or, at seasons when no rain falls, in the open air. It is to be illuminated and operated by electricity, either from a main supply, where this is available, or from a generator, and is therefore specially suitable for use in dark buildings or after dark in the open - at times when people are free of their usual daily occupations and therefore ready to be interested in new or unusual activities. Each illuminated or electrically operated element in the exhibition is fitted with a hand operated switch, which puts the light on, or starts the operation of the gadget, when the viewer grips a protruding handle, and then extinguishes the light, or stops the operation, when he releases his grip.

The public (prospective viewers) are first attracted to the exhibit by the projection upon a translucent screen, about 4 feet x 3 feet in size, of pictures, moving or still (a loop film, slides or loop filmstrip), upon the selected topic. This screen is embodied in the outside 'wall' of the exhibit, with the film, slide or filmstrip projector operating from inside, so that the pictures on the screen may be seen brightly illuminated by the general public outside.

If still pictures are used for the exhibition screen, the projection apparatus will be automatic, so that the coloured pictures on the screen change every minute. There are 12 pictures (frames) in the sequence, which, therefore, takes 12 minutes to pass through the projector, then repeats itself until the current is switched off.

At the same time a loudspeaker, operated from an automatic sound unit inside the exhibition, announces softly to the public outside a simple explanation of the exhibition and an invitation to come inside and see more. Close beside the projection screen is a clearly marked entrance in the 'wall'.

Once inside the exhibition the public find themselves guided by the layout of the walls and screens round its various sections, which are so arranged that the public absorbs its message in the following sequence:

- (a) A general introduction to the natural function of trees and their value to man;
- (b) A more scientific and instructional section dealing with the natural history of the tree (its cycle of growth and its effects upon soil, water supply and climate);
- (c) A demonstration of what happens when man indiscriminately cuts down trees (the evils of deforestation and erosion);
- (d) A motivational section indicating what action can be taken by communities to solve this problem by their own efforts with such aid as they can obtain from government and other agencies. Let us see how these different sections would be set out.

Facing the entrance to the exhibition, there is a screen which serves the purpose of directing the viewers to the left, where the exhibition proper begins. On this screen is printed in large letters, in the local language, a text which reads:

"A tree is the best friend of man,
it gives him timber for his house
it gives him wood for his fire
it gives him fruits to eat
it gives him shade to sit in."

Whatever may be placed upon this screen, as an alternative to this text, should not be so attractive, interesting, or difficult to read, that it will hold the attention of those who enter the exhibition and so cause crowding in the doorway. It is for this reason that we propose a text for the screen, which is decorative, but which has, in fact, no other value for the large proportion of viewers, who are illiterate.

Turning to the left, the viewer comes to another screen (the inner side of the outer wall of the exhibit) on which he finds four posters, illustrating graphically the four phrases of the opening text. The phrases are reprinted under each poster for those who are able to read.

The viewer next turns to three panels 2 1/2 feet x 4 feet. On each of these panels are mounted enlarged photographs, showing familiar trees and their products (fruit, timber, leaves for green manure, etc.) being used as they are used in the life of the local community. The photograph of the growing tree in each of these panels is a transparency (enlarged on 'translite' film) illuminated from behind to increase its visual impact. The remaining photographs, arranged around the transparency, illustrate the daily uses of the tree. This is an entirely visual exhibit with no text.

Next the viewer comes to the scientific and instructional section, dealing with the natural history of the tree and its effect upon soil; water supply and climate. He first looks down into a viewing box with a sloping top (16 inches x 48 inches) with three glass windows (each 9 inches x 9 inches) upon which are mounted three circular magnifying glasses 4 inches in diameter. Beneath each window and magnifying glass brightly lit by a hidden light (controlled by the standard type of switch) are three actual specimens:

The seeds of familiar trees;

A seed germinating, with the small leaves focused by the glass;

A second germinating seed, with the root fibres enclosed in a watertight glass container so that the formation of the roots in the water is visible through the magnifying glass.

The objective of this exhibit is not only to show the first stages of the growth of a tree, but also to introduce the viewer to the idea of magnification. He is able to see, through the plain glass surrounding the magnifying lens, the unmagnified object, and then, by looking through the lens itself, the magnified image.

On the wall above this magnifying box are a series of coloured diagrams, showing the seeds and young plants of a number of familiar trees.

Passing on from the low power magnifying box, the viewer comes to a second box, through the windows of which he can examine the root formation of the young tree, first under a higher powered single magnifying glass, and secondly, under a still more powerful lens securely mounted in the box. The actual objects displayed under the last of the low powered magnifying glasses and under the high powered magnifiers are identical. In this way, it is hoped to give the viewers an elementary conception of the process of magnification from lower to higher power.

The viewer now comes to a model of a growing tree in section. The central core of the root, trunk and branches are made in glass (for obvious reasons, plastic would be preferable and would indeed be essential for a mobile unit). To the viewer, it

appears as realistically as possible to represent a full-grown tree, cut down the middle. When he squeezes the handle beside the model, which corresponds in shape to the electric switches, the light goes on and coloured liquid (led into the exhibit through a rubber tube) passes up the glass core of the root, trunk and branches, and emerges through the 'foliage' of the tree as water vapour. At the same time a cloud, containing a hidden spray, simulates a shower of rain falling into the ground around the tree. Linked to this model, which is a central feature of the exhibit, is a sound element which tells the viewer, in simple language in the local dialect, through a muffled loudspeaker, what it is he is looking at. This short commentary tells him:

'A tree is a living creature.
Look at this model of a tree.
Squeeze the handle and you will see how the tree draws
water out of the earth.

Its roots draw water and food out of the earth to
give nourishment to the body of the tree.

Through its leaves the tree breathes. Through tiny
mouths in the surface the air is drawn into the
leaf.

And the moisture that is drawn up from the earth
sweats out through the leaves. So trees give
moisture into the air, which causes rain to
fall.

And when the tree loses its leaves, the leaves fall
to the ground and form humus in the soil. So
trees make your soil richer. Wise farmers
grow trees and use the leaves as manure.

When the monsoon comes the trees catch the rain in their
leaves and let it fall more gently on the earth
beneath. Their roots bind the soil with a sort
of net, so that the rain does not wash it away.

So trees improve your climate, enrich your land and
prevent the erosion of your soil.'

This exhibit has a special educational function to help the viewers to understand the nature of sectional drawings and models.

Next he passes to a screen on which he finds represented by diagrams, drawings and flat models, the essential functions of the roots and leaves of a full grown tree. Those are made in as simple a form as possible, with a minimum of explanatory text for those who are literate.

The viewer now comes to a series of three model boxes. Each box is so constructed that when he looks through a small rectangular window, 2 inches x 4 inches and presses the standard type of switch, he sees, brightly illuminated, a three dimensional model. One of these boxes (the middle one), is equipped with a sound unit so that the viewer, looking through the window, at the same time hears, from earphones built out from the viewing window, a simple commentary in the local language on what he sees.

This commentary says:

'Fifty years ago your land was rich, green and shady. Trees grew around your villages and fields. These trees provided your fathers with fuel and timber, and enriched their soil with humus formed from the falling leaves.

Now you are looking at the same land as it is today. You are chopping down your trees and lopping off the branches to feed your goats. Yet you never replant the trees, when you cut them down. So your land gets more barren and your crops yield less each year. You are destroying the trees which bring moisture to the air and protect the land from the heat of the sun and the damaging forces of rain and wind. You are depriving your land of the rich humus that comes from their leaves.

Now move to the next window, and you will see what your land will look like if you continue to destroy your trees. Later we will show you how you can prevent this devastation of your land.'

The first box contains a landscape, with miniature figures of men and animals, showing a beautiful countryside, rich with trees and ploughed fields; in the middle distance the blue water of a village 'tank' (rain water pond); and, below the dam, a garden of coconut palms and banana trees. This represents the landscape of the area as it was fifty years ago, in a period of happiness and prosperity.

The second box shows the same scene at the present day, with many of the trees cut down or mutilated, the irrigation system of the village tank partly destroyed, some incipient soil erosion, the garden below the dam somewhat neglected, the figure of a man chopping a tree, a boy lopping the branches of another tree to feed his goats, and women gathering now scarce fuel and fetching water from the half-dried tank.

The third box shows the same stretch of country as it might be fifty years from now, if no steps are taken to prevent the indiscriminate cutting and damaging of trees, the erosion of the soil and the general neglect of natural resources. In this last scene, the tank is almost dried up, except for two small pools of dirty water; and the dam, which should retain the water is badly damaged; a few decayed coconut stumps rise from the devastated garden, the cultivations are neglected and heavily eroded, a poorly dressed woman carries water from the dirty pools up an eroded path to an imaginary village behind the viewer, some emaciated cattle are seen looking for non-existent grass. This last scene is lit by a sunset from beyond the dead tree stumps. It shows the devastation that can come in tropical areas from neglect of the land and the destruction of its vegetable cover.

After the boxes, the public will come into the section of the exhibition which shows what should be done to replant trees and to prevent the damage caused by deforestation. First there are two models (3 feet x 2 1/2 feet) showing in full relief the two methods of planting trees in dry areas, namely, the 'Trench mound Method' and the 'Pit Method'.

Above these models, on a screen, are a series of coloured drawings with the leaves and seeds of the well known local trees and pictures of people making use of their products.

At this point a series of 12 flashboard posters made up into an album, is included. Each of the pictures (size 24 inches x 18 inches) has a caption. The captions read as follows:

"You sow Ragi"⁽¹⁾
"You protect it"
"You harvest it"
"You sow it again the next year"
"Again you harvest it"
"You cut trees for timber"
"You cut trees for fuel"
"Why do you not plant them again?"
"You grow Ragi"

(1) Millet.

"Why do you not grow trees for
your children?"

"Why do you not protect your trees as
you protect your Ragi?"

"If you do this your children will
remember you."

After these models and drawings comes a series of three stereoscopic (3-D) viewers, projecting from a screen in the wall of the exhibition in which the public can see colour slides in three dimensions. (Experiments are now being carried out with a 3-D viewer with an automatic slide changing device.) This will enable us to tell a story in 3-D pictures. At present however, the number of slides to be seen is limited to the number of viewers - i. e. three. These slides show again the actual planting and sowing of trees by the two methods recommended.

Finally, there comes a panel illustrating the importance of protecting trees from goats and cattle. This consists of a small tree with a protecting fence of thorns around it; and on the panel above it, two posters, illustrating the importance of keeping goats away from trees.

The height of all the items in the exhibitions is adjusted to the eye level of the adult of average stature. In order to enable children to enjoy the exhibition a stand with three rails is placed in front of each element.

As the public passes through the exit of the museum exhibition, they may be invited to help themselves to some simple literature, if this is available (e. g. single sheets setting out what the government undertakes to do if they are ready to plant trees, and small pamphlets describing what they, the public, can do and how to do it).

The supervisor of the exhibit will also be trained to give further advice and information to those who are interested in its subject.

The public will be invited and encouraged to visit the exhibit as often as they like."

CHAPTER II

CONSTRUCTING THE MUSEUM

On the basis of this plan and a simple budget, construction went ahead. Now the production specialists - the inner core of technicians - came into their own and worked with only occasional appeals for information or guidance to the other sections of the group.

It will perhaps be useful to describe briefly the general difficulties they encountered, the main features of the exhibition as they appeared when complete and the problems overcome - or not overcome - in their construction.

General Problems

The Unesco group was operating in an isolated rural area, ten miles from the town where supplies had to be bought and small engineering jobs done, and several hundred miles from the supply of more elaborate equipment and such services as colour film processing. No member of the group had had previous training in museum work, and advice from specialists might take several weeks to obtain by correspondence. Much time was, therefore, spent on supply problems and on experiments with model making in local materials. As a training exercise it was not wasted, but it indicated that there is a place for trained museographers in fundamental education projects, or a need for training to be given in well equipped educational museums to production specialists from fundamental education centres.

Electricity Supply and its Arrangement

The exhibition was to be set up in the training centre, which had main electricity; no particular problem was therefore encountered in running the current to each element through a switchboard and fuse box in a neighbouring control room.

Some experiments were made in constructing a type of strong pistol grip switch which could be fitted on six inches of flexible rubber hosepipe projecting from the wall beside each exhibit, but time and lack of tools made it impossible to construct the dozen or so that were needed. These would have enabled the different elements to have been worked and lit up by the viewers themselves, but this attraction had to be abandoned in favour of control from the outside switchboard.

Screens

The screens or 'walls' of the exhibit were made very cheaply of local fibre matting, stretched on wooden frames.

Projector and Translucent Screen

Beside the entrance to the exhibit, as planned in the manual, a translucent screen of local silk, 4 feet x 3 feet, was fitted into a partition wall.

The intention had been to project colour slides from behind the screen with an automatic slide projector which unfortunately, however, did not arrive in time for the exhibition. The film unit of the group therefore edited a loop of 16 mm colour film, showing the beauty and uses of familiar trees. This loop ran over a spool high in the roof of the building and repeated itself every two minutes on the translucent screen.

Photographs, Posters, Charts and other Graphic Media

The photographic transparencies - enlarged on 12 inches x 10 inches 'translite' film and illuminated from behind, were a special attraction, which exerted a noticeable impact in comparison with ordinary photographic enlargements on paper. Other two dimensional graphic materials for the exhibition were drawn and coloured by the team's artist.

The main problem here was to convey to illiterate peasants the rudiments of knowledge about the structure and life of a tree, in drawings, paintings and poster designs that were clear to them. Some tests, carried out on representative villagers by the psychology unit of the social science team indicated that many of the poster designs, although seemingly clear and simple, were not widely understood. However, what was never tested, as we shall later indicate, was the cumulative effect of the exhibits, and the degree to which each item, which may individually have been veiled in mystery, may have made some contribution to the general impression of the whole exhibit.

A very small amount of written material - simple captions or titles - was included in large lettering for the literate members of the audience, who might be expected, in this area, to be some 10% of the total. As far as possible, however, the exhibition was designed to be independent of the written word.

Magnification Boxes

In the two boxes, constructed for the magnification of living specimens of tree seedlings, the magnifying glasses of different power were held in place with screwed clamps over the square glass windows in the sloping tops of the boxes. The objects were illuminated by hidden bulbs inside the boxes and were mounted in water between two plates of glass 4 inches x 6 inches, separated (about 1/2 inch apart) by a strip of plasticine around the edges.

The Sectional Working Model

The sectional model of the tree caused, perhaps, more trouble than it was worth. The central core of the tree was made of glass, blown into the right shape by a local glassblower. The small tips of the glass branches were perforated so that coloured water, passing up the core, was emitted in a thin vapour from the 'foliage' of the tree. The section of the trunk of the tree was made of putty and the 'foliage' of plasticine. The cloud from which an artificial rain storm fell was similarly made with a glass tube bent at right angles, the top arm of which was perforated with small holes. Water was led by rubber tubes from a hidden bucket into the glass core of the tree and the artificial cloud.

The finished model was most artistic but far too delicate to be included in any mobile exhibition, and the artificial rain storm was apt to fall with such violence that the viewers were splashed in the face on turning the operating handle. Working models are undoubtedly a temptation to the ambitious and inventive producer of exhibits, but should probably be resisted under normal fundamental education conditions.

Models and Audio-Visual Model Boxes

The first elements to be constructed for the exhibition were two simple models, about 3 feet square, showing men planting trees. An armature of wire and gauze was fixed to a wooden frame and the 'landscape' was built on in putty and plasticine, surfaced with sand and powdered colours. The human figures - about 4 inches high were made of wire bent to form the bodies and limbs, with plasticine heads and muscles. They were dressed in dolls' clothes made from old cotton handkerchiefs and coloured with powdered water paints. The construction of trees called for some ingenuity - twigs formed the trunks, gauze and plasticine the foliage, feathers the palm fronds and coloured paper the banana leaves.

There was no doubt, however, that models lost much of their impact when exhibited on a table in the open, surrounded by distracting objects, which threw them out of scale and destroyed the illusion of reality. Model boxes of simple wood or hard wood were constructed, therefore, shaped like a squared off funnel, about a yard long and a foot to two feet high, with a viewing window at the small end. The models to be inserted in these boxes were made of papier mâché and finished with plaster of Paris and powder paint, as well as natural substances like sand, small stones, moss, lichen and twigs. The human and animal figures were carved from wood (by local craftsmen), or modelled in plasticine, and painted. An illusion of space was easily given by reducing the scale of figures and objects in the middle and further distance. So a landscape with a 6 inch human figure 6 inches from the viewer and a 1 inch figure 2 feet from the viewer seemed to be stretching away several hundred yards from the viewer's position and on into the distance beyond.

The audio-visual box.

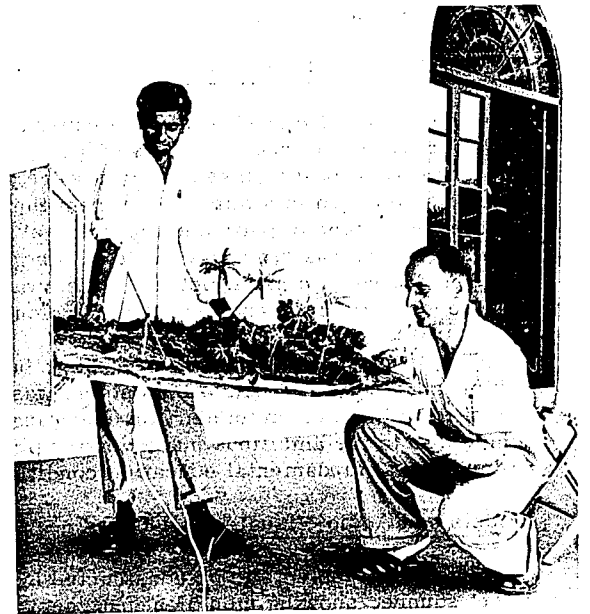

Inserting the model.



Viewing.

The models, brightly illuminated by bulbs hidden inside the box, gave a wonderful appearance of reality, and the viewer, with his gaze confined by the narrow aperture of the window and the painted sides of the box, felt himself to be identified with the scene before him.

Sound

It had been obvious to the production team from the beginning that the message of the exhibition would not be at all easy to convey to the audience by visual means alone. The written word was of course of little use for an audience which was so largely illiterate. It was agreed, therefore, that an oral ('talkie') element would be of the greatest value. Here the radio and 'sound' specialist in the training group was called upon for help. The plans for exhibit called for three small loudspeakers or earphones, one at the entrance associated with the translucent projection screen, another to explain the working model of the tree, and a third fitted to one of the model boxes. Each was to emit a short recorded commentary of about one minute's duration, repeated continuously at one-minute intervals.

Four alternative types of equipment were considered and the manual had set out what the team assumed to be the advantages and disadvantages of each.

"(1) A tape recorder playing a loop of magnetic tape.

Advantages:

The tape is durable and lasts up to several hundred playings;
The commentary can be re-recorded each day on the same tape or on a spare tape, by the exhibition supervisor, for use the following evening;
The sound is clear and that the volume can be easily controlled;
Running costs are comparatively low.

Disadvantages:

The original equipment is comparatively expensive;
For a mobile unit, it is delicate and rather easily broken;
It cannot be repaired, except by an electronic engineer.

(2) A dictaphone.

Advantages:

The commentary can be recorded daily;
The apparatus is perhaps less easily damaged than a tape recorder and therefore more suited to a mobile exhibit;
The play-back equipment is somewhat cheaper than a tape recorder.

Disadvantages:

The quality of the sound produced is not very high;
It cannot be played very loud;
Three pieces of equipment are necessary for recording, playing back and 'scraping' the cylinder or plastic belts.

(3) An electric gramophone turn-table, with an automatic arm adjusted to replay the same record continuously, fitted either with an electronic head and amplifier, or with an old type, non-electronic sound box and plastic tube leading to a horn or ear trumpets.

Advantages:

The play-back equipment is comparatively cheap;
It is not easily damaged or broken (this would be particularly true if a non-electronic sound box were used);

It can generally be serviced and repaired by someone (e.g. the exhibition supervisor) with limited special training.

Disadvantages:

The commentaries cannot be recorded by the exhibition supervisor, since the records (discs) must be cut on a special machine;

The records, if they are to be durable, lasting for at least one evening's playing, have to be made by a record manufacturing company and are expensive (it is assumed that an exhibition would have to be equipped with some hundred records of each commentary which would last for at least one hundred days of full operation; so, the cost, and the trouble and delay, of having the records cut from a locally made tape or disc recording would be considerable.

- (4) Film sound track, playing through a sound projector from a loop of film.

Advantages:

The sound projection apparatus would be comparatively strong;
The sound would be clear and the volume easily controlled.

Disadvantages:

The commentaries could only be recorded at a film studio, equipped for sound;
The producing and processing of the loop sound track would be comparatively expensive."

The manual concluded that "further experimentation is needed to discover the most suitable equipment for providing the sound element in the exhibition, which we regard as a most important element for use in areas of high illiteracy. Experiments with model boxes equipped with sound indicated that their appeal and impact is enormously greater than the effect of a similar visual element without sound."

Further experimentation is still needed, and machinery that could provide mechanical commentaries and is rugged enough for use in rural areas in the tropics, is still 'a most important element' for all types of exhibitions and demonstrations.

The Unesco team, being ill equipped for sound engineering, regretfully had to abandon its attempts to solve the problem of a permanent 'oral' element. Two ordinary magnetic tape recorders were, however, linked to small loudspeakers in the model tree and the viewing box respectively, and worked very well under close supervision.

Stereo-viewers

Finally the team had decided to try out the effect of stereo-photography. A number of colour slides, showing the 'trench mound' method of planting trees on waste land, were made with the aid of the group's 35 mm. stereo camera. Three stereo viewers were fixed into the wall of the exhibit with the eyepieces projecting towards the public. Here again the trials were a great success and the only cause for regret was that not more than three slides could be demonstrated - one in each viewer. Another type of viewer, which holds sixty slides and changes them at the pressure of a lever, was ordered from Europe but arrived too late for the exhibition. There is no doubt that 3-D colour photography has a real future as an aid to fundamental education and an element in the educational museum.

CHAPTER III

THE EXHIBITION COMPLETED: AN APPRAISAL

After four months' hard work the finished exhibition on Trees and the Soil was erected in the main hall of the Unesco Centre, in time for the farewell function that marked the end of the first training course.

Artistically and technically the exhibition was an undoubted success. As an instrument of fundamental education it was more difficult to judge, for lack of time at the end of the course prevented any attempt at a scientific evaluation of its educational effect.

Some five hundred villagers of all ages and both sexes - about 90% of whom were totally illiterate - swarmed through the exhibition during the day. Watching them, one was left with varied impressions.

It seemed that the static and graphic elements - posters, photographs and drawings - were scarcely considered, with the exception of the illuminated transparencies.

The working model of the tree was an object of mystified interest and admiration, but, even when the commentary was switched on, its message seemed too complicated to be fully grasped.

The magnifying boxes were a great attraction, and many of the audience were obviously excited by their first experience of magnification. Whether they realized any connexion between the beauty of the sprouting seeds, with their delicate roots and miniature leaves, and the general message of the exhibition is, however, extremely doubtful.

The realism of the stereoscopic (3-D) colour photography also had a very potent appeal and the slides seemed to be studied with understanding as well as interest.

Another object of remarkable interest was the album of 12 poster type pictures - in flash card form - which could be handled, turned over like a book and examined at leisure. Groups of villagers could be seen looking at this, while one of their number, often a small schoolboy, read aloud the captions written in large letters opposite each picture. Here, it seemed, that the inclusion of very simple written material, even for a largely illiterate audience, was vindicated.

There was no doubt, however, that the greatest impact was exerted by the audio-visual model boxes. As the manual suggested, the effect of automatic 'sound' was most impressive. A live demonstrator could never have commanded the wrapt attention that was given to the mysterious voice coming out of the box, nor could he have repeated at two-minute intervals the short, clear explanation that gave reality to what was before the viewer's eyes. When the sound was switched off, viewers would give only a cursory glance at the silent model. Then, as the sound came on, they would crowd back for a second view and each would remain with his eyes glued to the viewing window, listening intently to the soft voice that explained in his own dialect, simply and personally, what he was looking at. The trials of this audio-visual, three dimensional model box indicated that it may well be among the most effective audio-visual aids for fundamental education.

Whether or not the exhibition succeeded in changing the attitudes or modifying the actions of the villagers in regard to the deforestation problem, it was certainly a source of obvious pleasure and interest to them. It was, indeed, the opinion of those who watched the experiment, that an exhibition of this type, if used, not as an exercise in training, but as an element - an audio-visual aid - in a continuous campaign, would undoubtedly have quite an exceptional impact on the minds of its audience.

CHAPTER IV

A SECOND EXPERIMENT IN MYSORE

The experiment just described, carried out by the first Unesco training group, was followed by another and rather different project, undertaken by the second group. This second experiment differed in several respects from the first. It was an attempt to use simple exhibition techniques in the open air - in the village. It took as its subject Market Gardening. It was designed as a two-day exhibition and was sited in a demonstration garden, which had been developed by the Unesco group in co-operation with a small landowner in Yelwal village, half a mile from the Centre. But from the point of view of this record the most important feature of the experiment was that it included a modest but systematic attempt to use simple evaluation techniques to assess and improve the effectiveness of the exhibition. The experience gained was sufficient, at least, to convince the Unesco group that this type of 'built in evaluation' is an indispensable feature in the production of educational materials in general, and museum exhibitions in particular, for fundamental education in largely illiterate societies.

The progress report of the second training course gives the following account of this experiment.

"It is clear that the development of horticulture in our area needs a continuous educational programme for a long period. With this idea, we concentrated during the period under review, on making a series of filmstrips on various aspects of horticulture and in setting up a village horticulture exhibition in our model garden in Yelwal.

This exhibition was one of the highlights of our course. The owner of the garden, Mr. Sampath Iyengar, co-operated eagerly with our horticulture team in setting it up. Members of the group who were specializing in the production of audio-visual materials spent hours in constructing new models from papier mâché, plasticine, feathers (for palm fronds) and orange pips (for coconuts) to fit into the audio-visual viewing boxes, described in previous reports of our Museum Exhibition Unit. One model showed a neglected garden, water-logged and choked with lantana scrub, the other a productive garden, with a man working the hand lift irrigation system and a woman gathering vegetables from the well grown plots. Viewers looking through the windows at the brightly lighted models would hear through two loudspeakers, connected to our tape recorders, soft voices telling them in their own language:

"Look at this land. Is this a garden? It is water-logged and choked with lantana scrub. There is nothing but a few coconuts to serve as food for the monkeys. Now look in the next window."

"Look at this garden. How beautiful it is. The gardener has put a fence round the garden to keep out goats and cattle. He has a 'pikota' and waters his land. He has made channels and the water flows freely round the garden. Soon he will have an irrigation pump. Look at his cabbages. He can sell each one for 8 annas. You can make a good living by market gardening."

The model boxes occupied an important place in the middle of the exhibition. A half-size model of a hand lift irrigation system, showing various technical improvements on the local type, was constructed in the garden. Many improvements in gardening practice - the layout of seed beds, composting and green manuring, soil improvement, fruit propagation by budding and grafting, and pest control - were exhibited with clear, descriptive labels. The Electricity Department of Mysore State generously agreed to run a line into the garden and to demonstrate an electric pump. From the same power line electricity was carried to our audio-visual boxes and to a home-made daylight filmstrip projection box, which enabled us to give illustrated talks to groups of visitors.

The Department of Horticulture of Mysore State gave us wholehearted co-operation in our project, sending us expert advisers and numerous specimens of high quality

vegetables, pests and other exhibits. A local horticultural farm set up a stall of pest control devices, which were demonstrated to our visitors. A plant pathologist and specialist in coconut cultivation, came from the Department of Agriculture, Bangalore, to give demonstrations of improved methods of coconut growing, which were a most popular element in the exhibition.

A poster announcing the garden exhibition had been prepared some weeks in advance and printed on our improvised silk-screen equipment. This poster was exhibited in the surrounding villages. With our Fordigraph duplicator we printed large numbers of invitations in Kannada and distributed them to the village leaders in the area. In spite of these efforts at publicity, the attendance at the show was not very large. We could keep no record of visitors, but we estimate that some 400 people came to the exhibition. However, the intense interest shown by our visitors fully compensated for the rather small attendance. The show continued for two days, and might well have run for a third, had we realized that numbers of villagers would come in on the third morning, as news spread that the exhibition was worth seeing. On the second day the staff and forty students from a Village Level Workers' Training Centre visited the show. This group, and many of the government officials who assisted in the project, showed a very lively interest in the techniques we had used and asked us to assist them in working up similar exhibits at their Centre and for a forthcoming horticultural show at the local town.

In our course we had always emphasized the importance of evaluating all projects and activities planned within a fundamental education programme. We therefore prepared a series of questions and briefed our Kannada-speaking assistants to waylay and interview visitors in the exhibition, in order to obtain their reactions. The results of this limited evaluation were analysed on the evening of the first day and a number of changes and improvements in various exhibits were made in time for the second day's show. Unfortunately one of the defects which this study revealed was that our visitors were not able to understand all the exhibits, since they could not read the notices and labels. We were forced to divert our Kannada-speaking assistants from evaluation to the task of guiding visitors and explaining the exhibits to them. This meant that our evaluation was practically limited to the first day, and does not, therefore, reflect the reactions of our visitors to the exhibition as it was after the improvements had been made."

The rather rudimentary evaluation mentioned in this account taught the production team much about the reactions of the audience. It indicated for example, that a large-scale model of a hand lift irrigation system, built to half natural size, was not understood as a model, but as the real thing, constructed smaller than usual for some uncertain purpose, for - as most people thought - children to operate. It confirmed the opinion, formed after the previous experiment, of the great educational value of the audio-visual model boxes and the importance of the sound element in attaining their full potential. Finally it indicated that even the simplest exhibits have a comparatively limited impact on illiterate viewers, unless they are explained orally by demonstrators, or by mechanical voices. But above all the exercise in evaluation showed how important evaluation is in itself to guide the production of educational media for uneducated audiences.

CONCLUSIONS

These two experiments in applying museum exhibition techniques to fundamental education under typical conditions in an underdeveloped rural area, were no more than a tentative beginning - an incidental activity in a temporary training scheme. They will, however, have served their purpose if they lead to further thought and action, not only on the part of the thirty-eight student specialists in fundamental education who carried them out, but also of those who read this account. Perhaps, therefore, the present writer, who initiated this project and followed it critically, ought to suggest here the rudiments of what might be done to follow up these first experiments.

When we speak of using museum techniques for fundamental education it is important to be clear as to what we mean by fundamental education and what sort of museum techniques we have in mind. The official definition speaks of fundamental education as: 'that kind of . . . education which aims to help children and adults who do not have the advantages of formal education to understand the problems of their immediate environment . . . and to participate more effectively in the economic and social progress of their community'. It is, therefore, concerned to bring new ideas and new knowledge to people who may be illiterate, but have generally a very real experience of life in all its local implications. It may also be concerned to change attitudes and motivate action, especially co-operative action.

What kind of 'museum' is required for these tasks, for fundamental education, for bringing new ideas to those who do not have the advantages of formal education, for changing attitudes in iron age societies? What seems to be needed, at first, is the simple educational exhibition, whether in a permanent museum or a mobile unit or both. It should be clear and direct in its message. It should concern itself with a single topic of local importance (though the topic may be quite frequently changed). It should be topical also in the sense that its frame of reference is local and immediate, based firmly upon the knowledge and beliefs of its audience, 'starting from where the people are'. It should fit into a scheme of other educational activities and into a wider programme of community development, so that it effects its audience, not as an isolated event, but as part of a continuous educative process.

The opinion is frequently expressed that 'gadgets' are not effective in a museum exhibition for illiterate audiences. This opinion is based on the conjecture that the audience is amused or interested by the working of the gadget and consequently does not absorb its message. 'Gadgetry' for its own sake, is obviously to be deplored, but the experience of the Mysore project seems to indicate that purposeful gadgets, like audio-visual model boxes and stereoviewers, may have a very real educational value and give life and interest to what would be, without them, a dull and inert exhibition.

One thing is certain: the production of an educational museum exhibition requires a high degree of skill and ingenuity in the constructional artists - the production specialists. Those who have worked in underdeveloped areas will perhaps recall the battered exhibits of crops and pests, the unintelligible charts and graphs, the cracked plaster models of 'model villages' that no human being would wish to inhabit, put together by local artists at the behest of amateur enthusiasts in community development, and inflicted upon apathetic audiences as 'educational exhibitions'. Better no exhibitions than these!

But perhaps more undesirable still is the good exhibition, which says the wrong thing in the right way. It is vitally important and extremely difficult to ensure that the message of any exhibition is a valid one - that it tells people to do what they can do, and what they should do, in the right way and for the right reasons; and the more effective the exhibition is, the more important this becomes. This demands that the exhibition be based on a careful study of the topic in its technical aspect and in its local context, and upon an equally careful study of local opinions and attitudes about it. In short its planning and construction demand close team work between production specialists, fundamental education specialists, social science specialists and topic specialists.

And finally, if the exhibition is to have full educational effect, its components and finally the whole exhibit, must be tested on sample consumers during production, to ensure that they are understood - that they convey the ideas they are intended to convey or arouse the emotions they are intended to arouse.

This built in evaluation or consumer research is another function of the social science specialist in the production group and should be regarded as an essential feature in the production of all types of fundamental education materials.

A Fundamental Education Museum Service

Let us imagine a fundamental education centre, staffed and equipped, as are a number of regional and national centres, for experimental study, production of educational material and training. Its production staff would normally include artists and photographers. A trained museum officer would be introduced and would be responsible for designing and constructing exhibits. Fundamental education, topic specialists and social anthropologists would be at hand to work in the production team. Educational materials and trained field workers would radiate from the centre over a broad cultural and linguistic area - perhaps the greater part of a country. (What is now called 'built-in' evaluation would, in fact, be a regular control on all production activities of the centre.)

This then would be the setting for a museum experiment.

First, in the centre, or in the nearest market town where the people of the area congregated, a small permanent fundamental education museum would be established - one spacious room should be enough.

A programme of exhibitions would be worked out, in conformity with the plans of the centre and the needs of the areas which it served. The skeleton of the exhibition - the model boxes, slide projector, sound installation, stereo-viewers, transparency frames and other gadgets, would remain more or less the same. (This does not of course preclude the exercise of ingenuity in improving designs and varying layout and presentation.)

Perhaps four times a year the topic would be changed. One can imagine a whole range of exhibitions for example on agriculture, health, home economics, housing and community planning, and rural industries. The topics would not be hard to select - market gardening, irrigation, fertilizers and manures, insects and disease, village sanitation, food preparation (with a trained home economist giving free demonstrations to the women for 2 hours a day), the ideal home, pottery (with demonstrations of improved techniques based on very careful local experiments to determine what can and should be done to improve the craft, within the limitations of local markets, skills and materials).

Later perhaps, but not at first, there might be a permanent rural museum, beside the educational exhibition room, to house an exhibition of local history, culture and art. But first let the museum habit grow by the direct and simple impact of educational exhibitions.

As each exhibition took its place in the museum, production would begin on the next topic. So, when the time came for the change of topic, new models would be fitted into the boxes, new commentaries recorded, new 'stereo' pictures and colour slides inserted in viewers, and projectors. Each item of the exhibition, and finally the complete unit, would be tested, and modified, during production.

Based also on the fundamental education centre would be a number of mobile exhibition units. Whether they were luxuriously equipped motor vans or units designed to be packed in trailers or ox carts, or even to be loaded on mules or bicycles, would depend upon the budget available and the communications in the area.

In this connexion it may be appropriate to quote the concluding sections of the Mysore group's manual:

"We have described a unit which can be constructed as a static exhibition or as a mobile one, according to the purpose to be served and the funds available. Either type could, of course, be produced more modestly at less cost. The mobile unit is inevitably more expensive, but for obvious reasons, it should have a wider influence on scattered rural communities.

It should be remarked that the rather costly audio-visual equipment - projectors, sound recorders and 'play-backs', and the generating plant - which give the unit its full potential of power, are the normal equipment of a mobile audio-visual (cinema and radio projection) unit, such as is used in many countries for fundamental education. We therefore feel that the exhibition unit should be regarded not so much as a new and independent medium, but rather as an expansion of an already established instrument of fundamental education and extension work, designed to give it additional educational strength.

If the exhibition supervisor is also trained as projectionist and commentator, and is suitably equipped with a variety of films, filmstrips, and records, the unit can be used to give normal village performances of films, filmstrips and public address broadcasts. Using the same equipment, with the addition of graphic and three dimensional materials and various gadgets, such as model boxes and 3-D viewers, the unit operates as a mobile exhibition. In this capacity, it has a number of advantages over the ordinary cinema-radio unit:

The concentration of various media on a single topic;

The sustained impact of an exhibition, arising from the fact that people can absorb its message at their own speed, and return to it again and again;

The novelty and variety of the presentation.

Looked at in this light, a mobile exhibition unit is not an expensive new luxury, but an elaboration of an accepted educational unit, which, with not much extra cost and trouble, can make more continuous, effective, and therefore, economical use of its standard audio-visual equipment."

Whatever form the mobile units might take, their basic structure should not differ widely from that of the permanent fundamental education museum. As each new exhibition on a new topic was installed in the static museum the contents of the previous one would be transferred, with the necessary adaptation, to a mobile unit. So a programme of rotation would be established which would keep one, two or three mobile exhibits travelling, while one was being refitted, in the centre, with the last exhibition from the static museum.

This is, of course, no more than a conjectural plan. But then, it must be admitted that in the matter of using museum techniques for fundamental education we are still in a conjectural stage. The experiment carried out by the Unesco group in Mysore was no more than a reconnaissance, which discovered some of the technical and educational problems. What is now needed is experimental work in the field, linked with systematic evaluation. Techniques perfected in urban educational museums must be readapted to the realities of work in fundamental education. Equipment, such as projectors, stereo-viewers and electric generators, must be tested under tropical conditions and in the hands of local operators. Production methods must be evolved that give equal emphasis to constructional efficiency, topical validity and educational effect. Testing and evaluation methods must be perfected for discovering this educational effect and so for guiding the production of exhibits. In these experiments, and in the vast field of activity which they will open up, museums will accept the challenge to provide a new and vital service to fundamental education, and thus to the social, cultural and economic advancement of under-privileged societies.

The reader of this monograph will be interested in the specialized review published by Unesco in this field:

FUNDAMENTAL AND ADULT EDUCATION. A quarterly bulletin. A technical journal intended mainly for specialists in fundamental and adult education, though the documents and information contained in it are within the scope of all those interested in educational problems. It contains articles describing important activities in fundamental and adult education, and statements about programmes and general lines of policy.

Any of the Unesco national distributors will accept subscriptions; rates in currencies other than the above will be supplied on application to the national distributor in the country concerned. For information please write to Unesco, 19 avenue Kléber, Paris 16e.

UNESCO COUPONS

We should like to draw the attention of our readers to the Unesco Coupon Scheme, which may enable them to purchase materials listed in this periodical. Because it is often difficult to send money from country to country for the purchase of books, films, laboratory equipment, etc., Unesco has created a sort of international currency, the UNESCO COUPON. These coupons enable schools, universities, teachers and students in many parts of the world to buy freely the materials which they need for study and research.

UNESCO COUPONS can be used to buy:

books	the following categories of educational films:	various categories of scientific material for education and research, such as:
periodicals	(a) screening prints and duplicate prints	optical instruments, balances and weights
photocopies	(b) original negatives and duplicate negatives	laboratory glass-ware
microfilm copies	as well as	electrical measuring instruments
art reproductions	(c) 16mm. raw film for printing the above categories of films	analytical and clinical testing apparatus, etc.
charts, globes, maps, sheet music		
gramophone records		

UNESCO COUPONS are on sale in most Member States which have currency restrictions. If you do not know where to obtain coupons, please consult your National Commission for Unesco or write to Unesco, Paris, for the information.

The TRAVEL COUPON SCHEME, which is designed to overcome the currency barriers to educational and cultural travel, is an extension of the Unesco Coupon Scheme described above. Travel Coupons are a form of international travellers' cheque. They provide the foreign exchange needed to enable travellers such as students, teachers and research workers to spend time abroad for study or research.

For full details, please refer to the following explanatory leaflets:

UNESCO COUPONS

with separate addenda on

BOOK COUPONS

FILM COUPONS

COUPONS FOR SCIENTIFIC MATERIAL.

INTRODUCING THE UNESCO TRAVEL COUPON

(containing the addresses of the national agencies responsible for the allocation and issue of coupons, and the banks where they may be cashed).

which may be obtained upon request from the:

UNESCO COUPON OFFICE

19, avenue Kléber,
Paris - 16e (France)

ERIC Clearinghouse

NOV 25 1970

on Adult Education